

FYST17 Lecture 10

The Higgs discovery

Thanks to A. Hoecker, F. Gianotti, J.
Incandela

Outline

- The Higgs boson and the Standard Model
- Production and decay at the LHC
- Elements in an analysis
- 2012 "discovery"
- Latest status

The Standard Model in one slide

Quarks



Forces

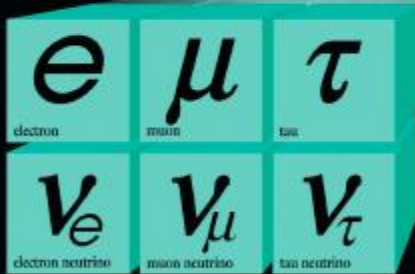

Leptons

+ anti-particles!

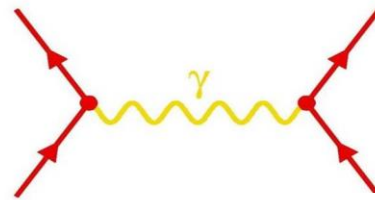

Electromagn. Int.

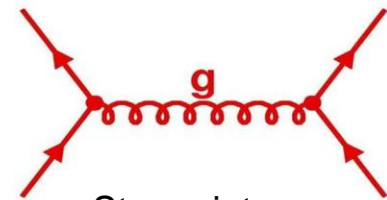

Strong int .

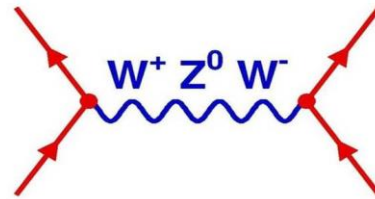

Weak int.

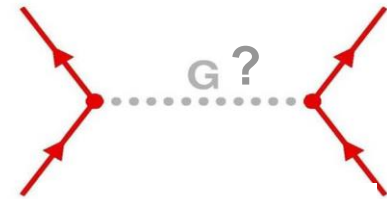

Gravitational int.?

Eksistence of **Higgs boson** to give mass to the other particles

2. and 3. generation unstable
Decay via weak interaction

The Standard Model in one slide

Quarks



Forces



Leptons

+ anti-particles!

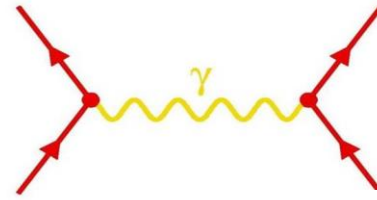

Electromagn. Int.



Strong int .

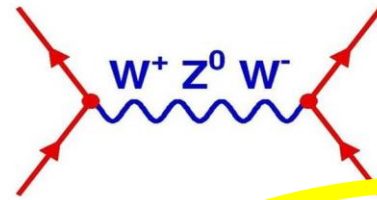

Weak int.



Gravitational int.?

Eksistence of **Higgs boson** to give mass to the other particles

2. and 3. generation unstable
Decay via weak interaction

The Standard Model

Elementary particle physics is successfully described by **local gauge theories**

A problem: local gauge symmetry requires **massless spin-1 “gauge” (=force) boson**

This has been well verified for QED, with a massless photon (= infinite range)

However, the **W, Z bosons are massive** (= finite range $\sim 10^{-15}$ cm)

Only way to break gauge symmetry consistently is to **spontaneously break the symmetry of the vacuum:**

$$M_{Z,W} \neq 0 \quad \Leftrightarrow \quad \langle 0 | \phi | 0 \rangle = v \neq 0 \quad [\text{non-zero vacuum expectation value}]$$

ϕ is a complex doublet field with non-zero vacuum expectation value.

3 d.o.fs become Z, W^\pm masses, remaining d.o.f is **massive scalar Higgs boson**

This is known as the **“Englert-Brout-Higgs-Guralnik-Hagen-Kibble Mechanism”**

or simply **the Higgs mechanism**

The Standard Model

Englert-Brout-Higgs-Guralnik-Hagen-Kibble mechanism

The early universe, at $T > T_{EW}$, was in a symmetric phase ($|\phi_{min}| = 0$)
A phase transition at $\sim T_{EW}$ (10^{-10} s after big bang) led to $|\phi_{min}| > 0$

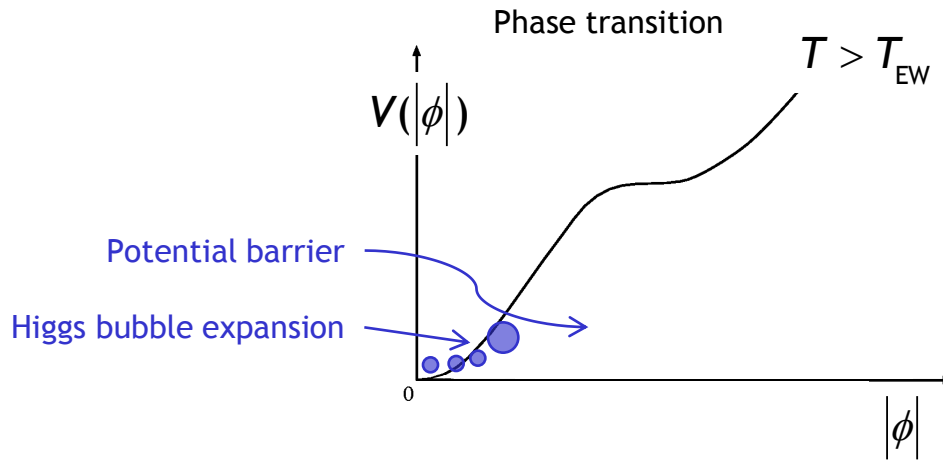

The Standard Model

Englert-Brout-Higgs-Guralnik-Hagen-Kibble mechanism

The early universe, at $T > T_{EW}$, was in a symmetric phase ($|\phi_{min}| = 0$)
A phase transition at $\sim T_{EW}$ (10^{-10} s after big bang) led to $|\phi_{min}| > 0$

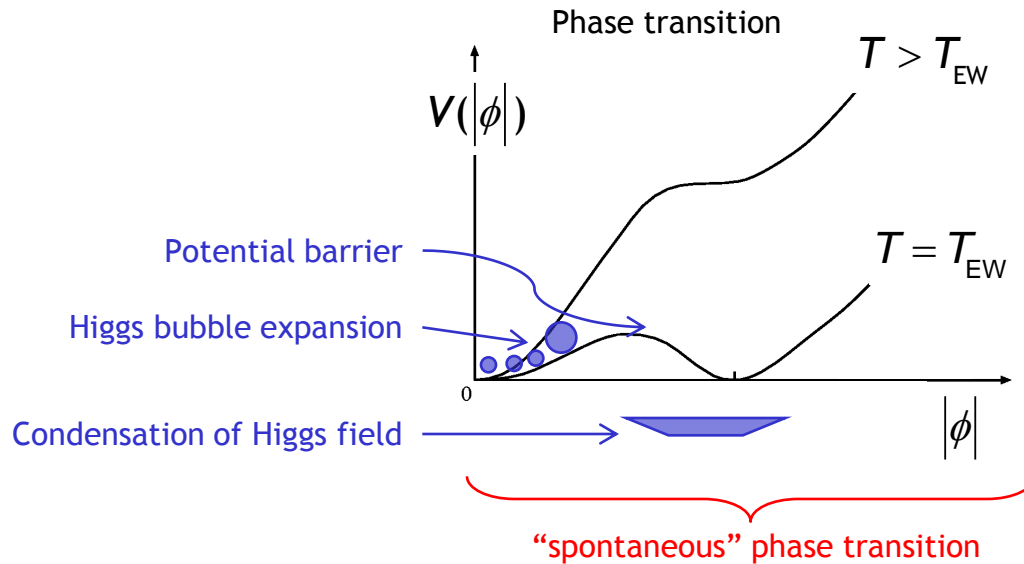

Higgs potential:
$$V(\phi) = \mu_{<0}^2 |\phi|^2 + \lambda |\phi|^4 + Y^{ij} \psi_L^i \psi_R^j \phi$$

Simplest scalar potential that breaks ground state symmetry. Does what we need, but bears fundamental problems.

Carries the seeds for new physics ...

The Standard Model

Englert-Brout-Higgs-Guralnik-Hagen-Kibble mechanism

Early universe: symmetric phase, fundamental particles are massless
⇒ gauge symmetry is respected

A **Higgs field** displaces ground state breaking gauge symmetry

It fills all space time (but w/o orientation as spin=0)

Particles interact with the Higgs field and reduce their velocity.
They acquire a mass proportional to interaction strength

⇒ Action of the Higgs field creates a **vacuum viscosity**

Symmetric phase - early universe
Higgs quantum liquid in broken phase

Gravity 

Photon 

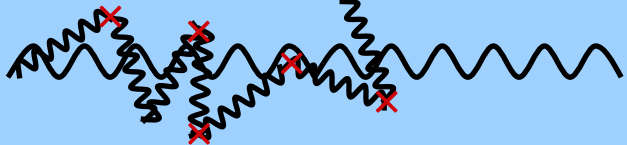
Weak boson 

Neutrinos 

Electrons 

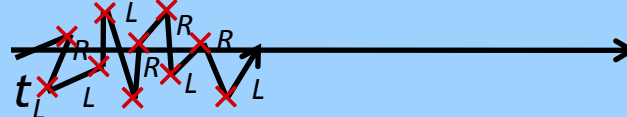
Top quark 

The Higgs boson should not be too light, and not too heavy...

Perturbativity and (meta)stability bounds versus the SM cut-off scale Λ

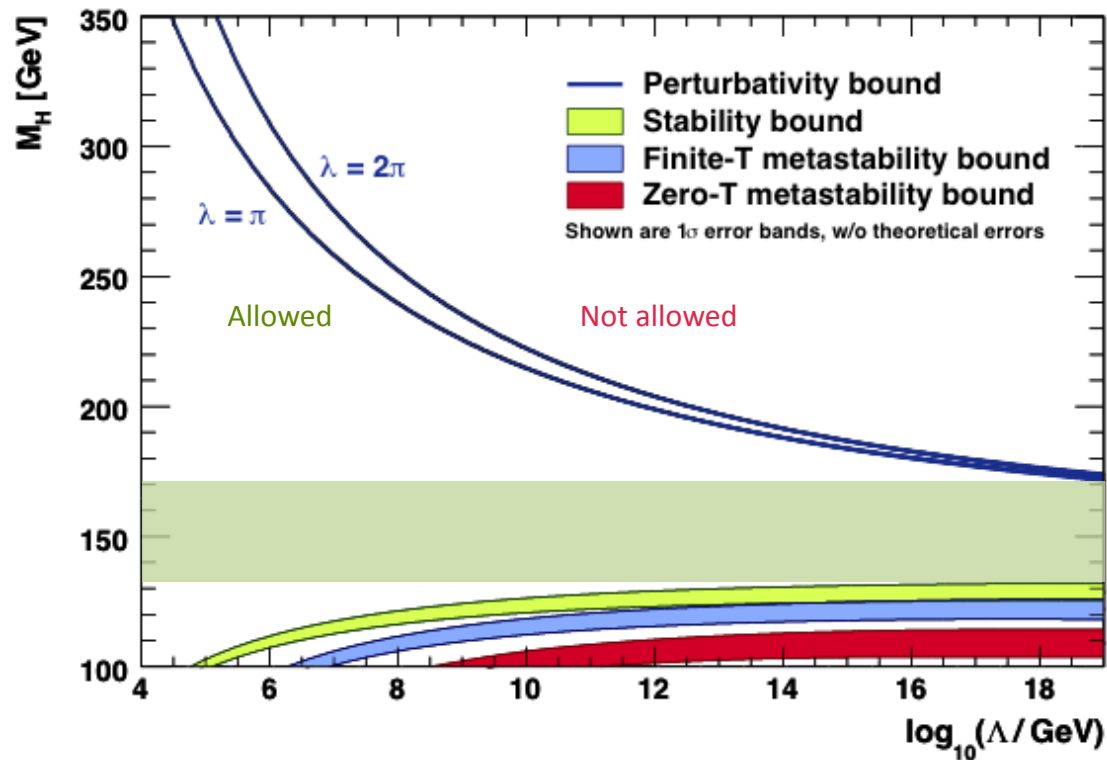

The SM Higgs must steer a narrow course between two disastrous situations if the SM is to survive up to the Planck scale $M_p \sim 2 \times 10^{18}$ GeV

Higgs production at the LHC

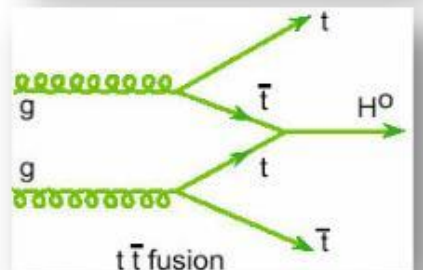
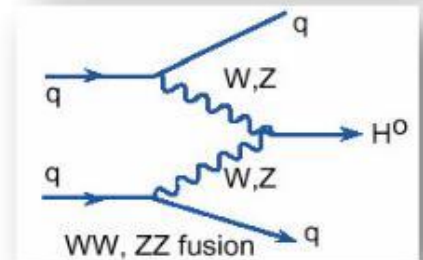
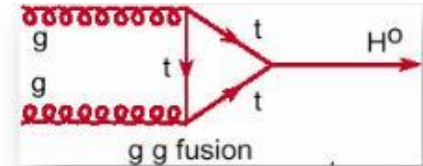
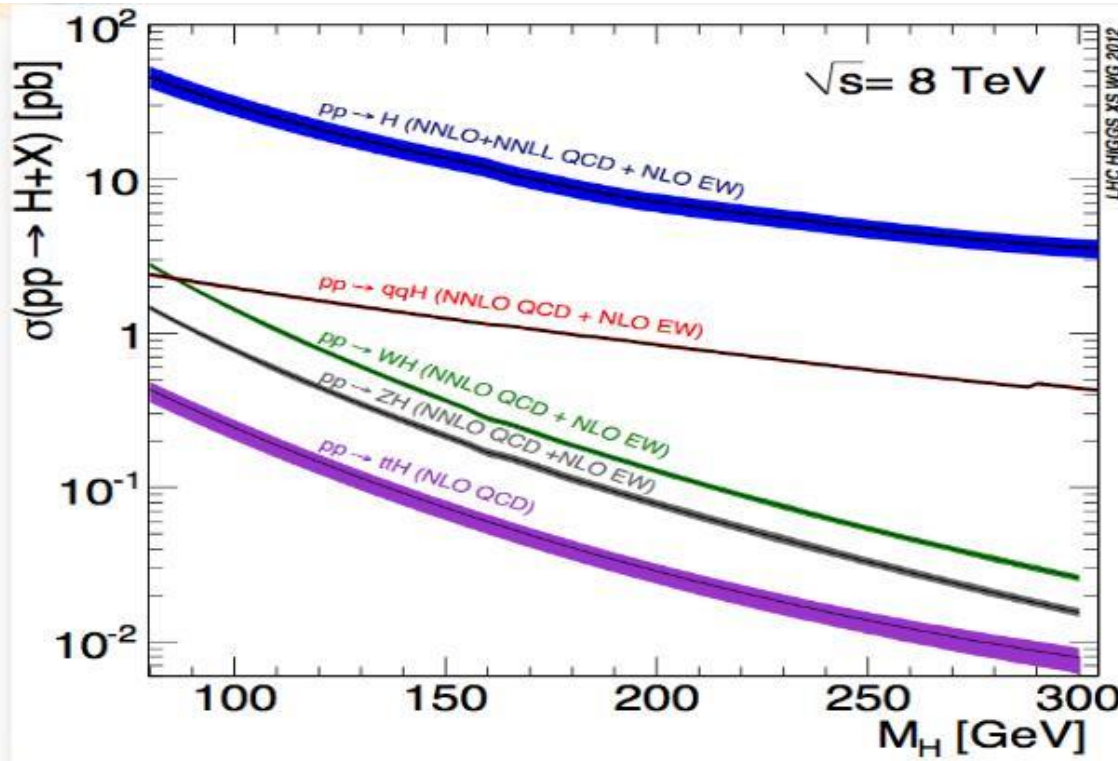

- $\sqrt{s}=8$ TeV: 25-30% higher σ than $\sqrt{s}=7$ TeV at low m_H
- All production modes to be exploited
 - gg VBF VH ttH
 - Latter 3 have smaller cross sections but better S/B in many cases

Most important decay modes

5 decay modes exploited

- High mass: WW, ZZ
- Low mass: $b\bar{b}, \tau\tau, WW, ZZ, \gamma\gamma$
- Low mass region is very rich but also very challenging:
 main decay modes ($b\bar{b}, \tau\tau$) are hard to identify in the huge background
- Very good mass resolution
 (1%): $H \rightarrow \gamma\gamma$ and $H \rightarrow ZZ \rightarrow 4l$

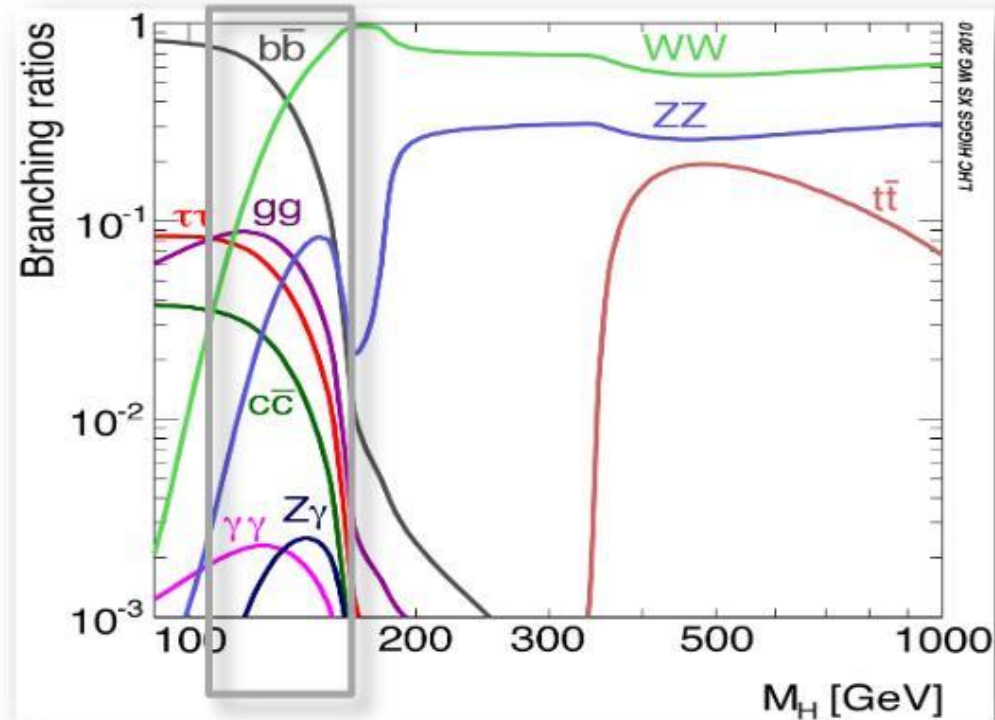

4th of July, 2012 – Higgs-day at CERN

Global Effort → Global Success

Results today only possible due to extraordinary performance of accelerators – experiments – Grid computing

Observation of a new particle consistent with a Higgs Boson (but which one...?)

Historic Milestone but only the beginning

Global Implications for the future



Trigger on Higgs bosons?

Several triggers in use:

Main triggers: lepton/photon triggers

but even tau (had) triggers

jet triggers and a trigger

on "missing E_T " (for the

$ZH \rightarrow \nu\bar{\nu} b\bar{b}$

Final analysis uses a

combination of several triggers, several "channels" for maximal sensitivity

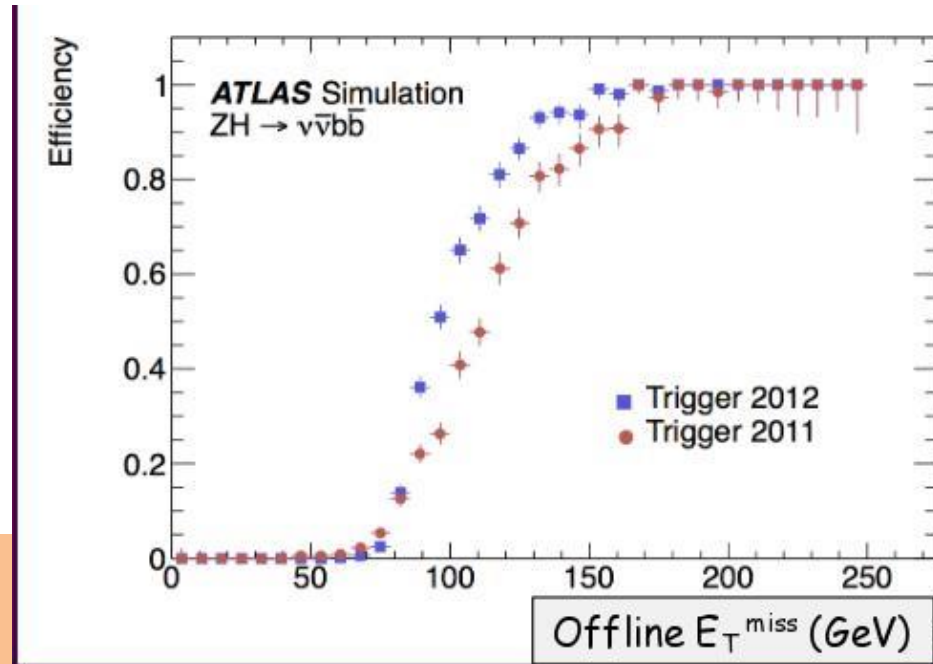

Reconstructing photons

Without a track, can we tell the difference between γ and π^0 ?

Crucial for $H \rightarrow \gamma\gamma$ search!

ATLAS uses the fine segmentation of the EM calorimeter to measure γ direction

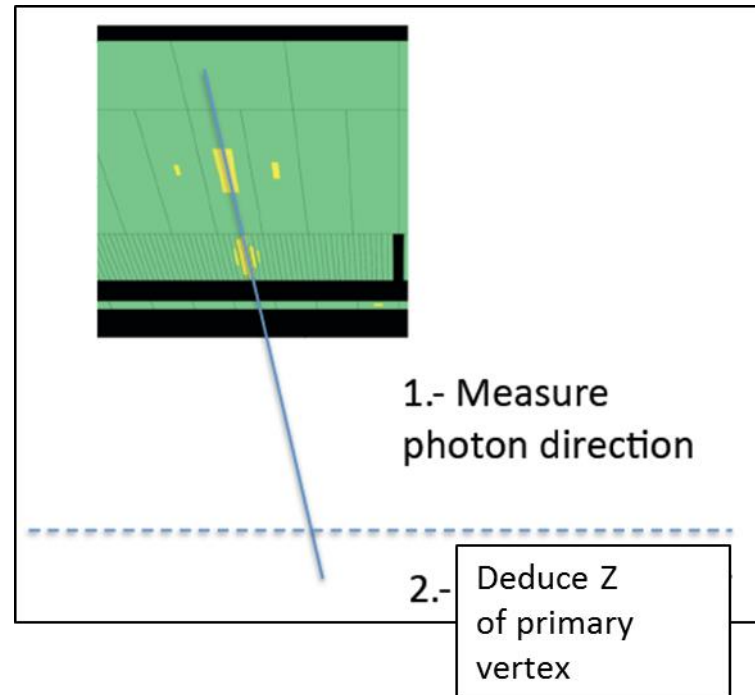
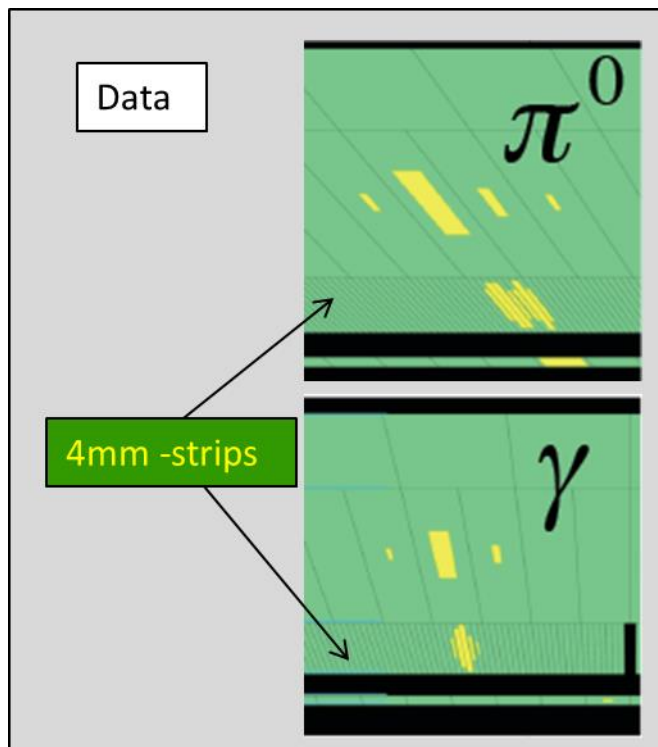

Reconstructing photons

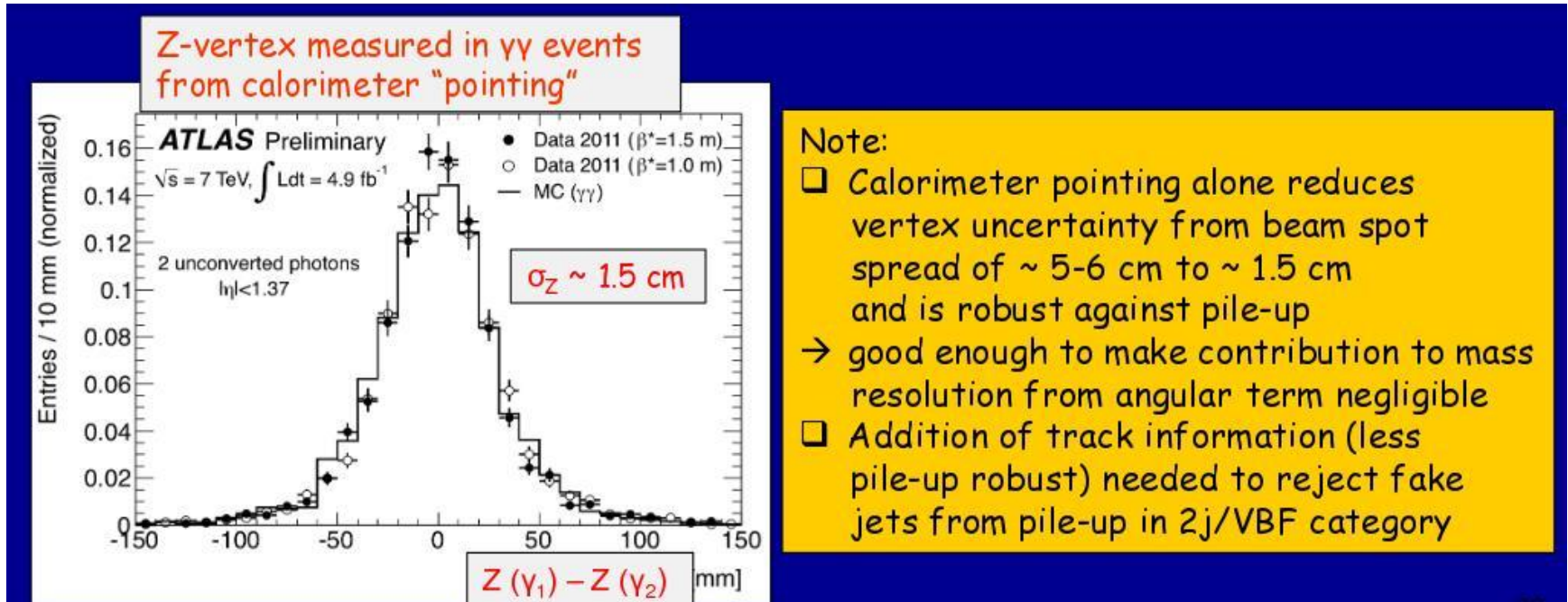

In addition of course also mass resolution is crucial

$$m_{\gamma\gamma}^2 = 2 E_1 E_2 (1 - \cos \alpha)$$

Resolution 1.6 GeV (linearity + uniformity terms $\sim 1\%$)

Reconstructing leptons (e, μ)

Typically reconstructed with high efficiency

- electron selection based on likelihoods and multivariate techniques to reduce backgrounds

Gaussian Sum Filter allows for reconstruction of e tracks with large bremsstrahlung

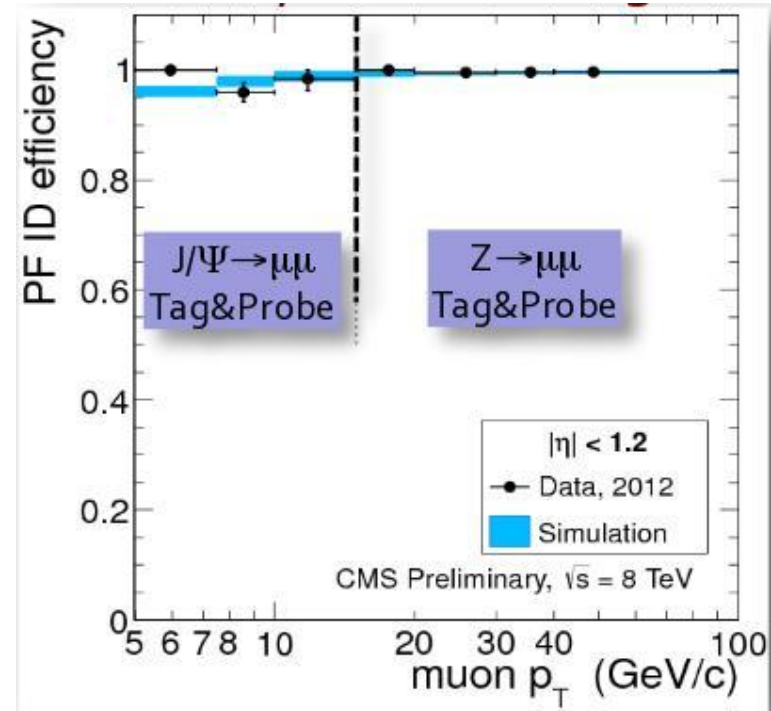
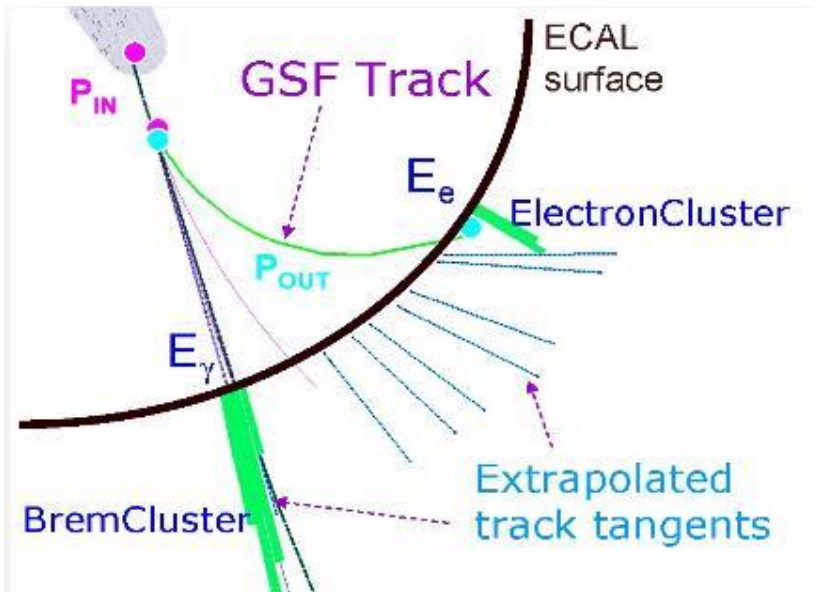

Computing

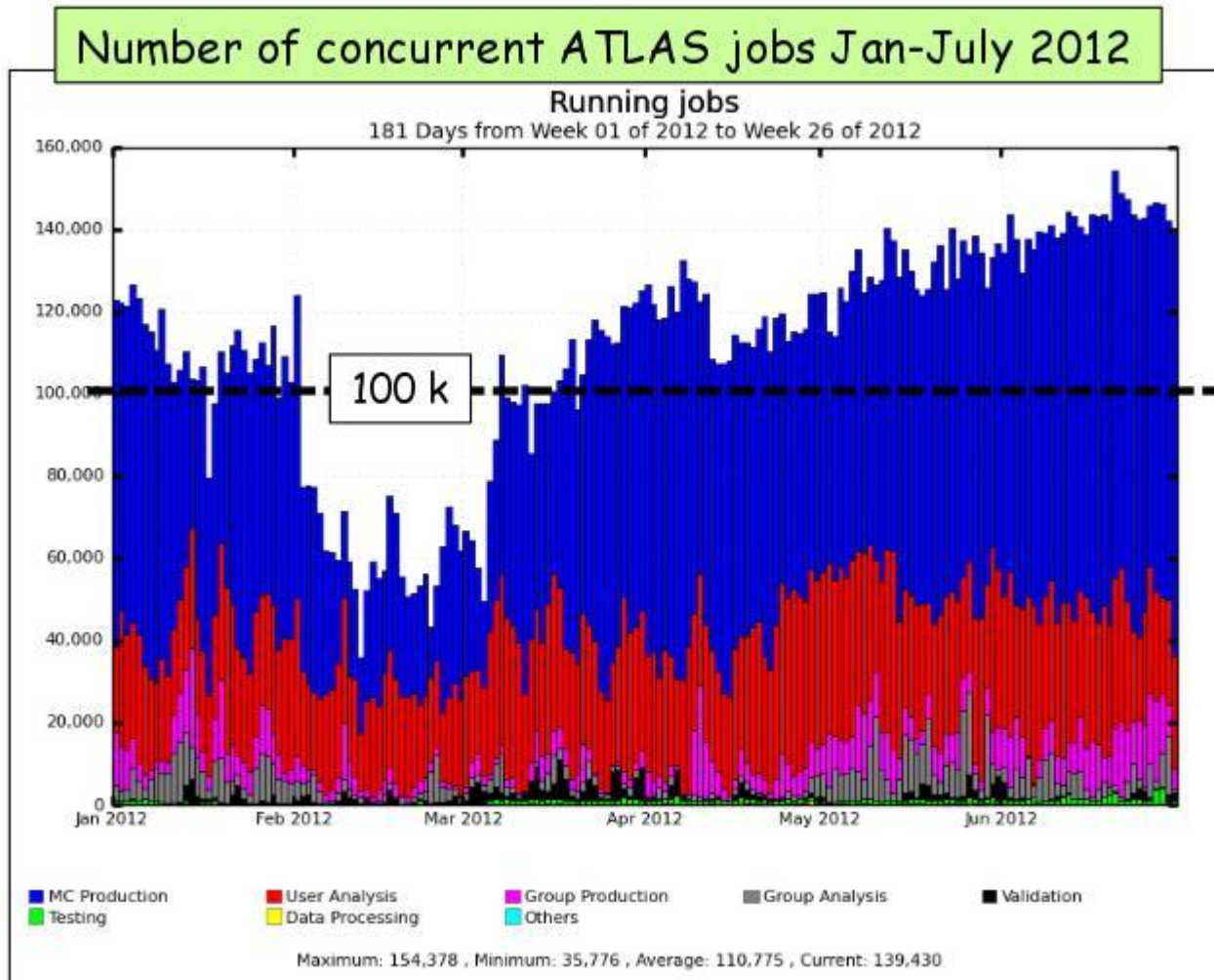

$$H \rightarrow \gamma\gamma$$

Most important channel for Higgs masses below
150 GeV!

Simple topology but large backgrounds \Rightarrow
requires excellent energy resolution

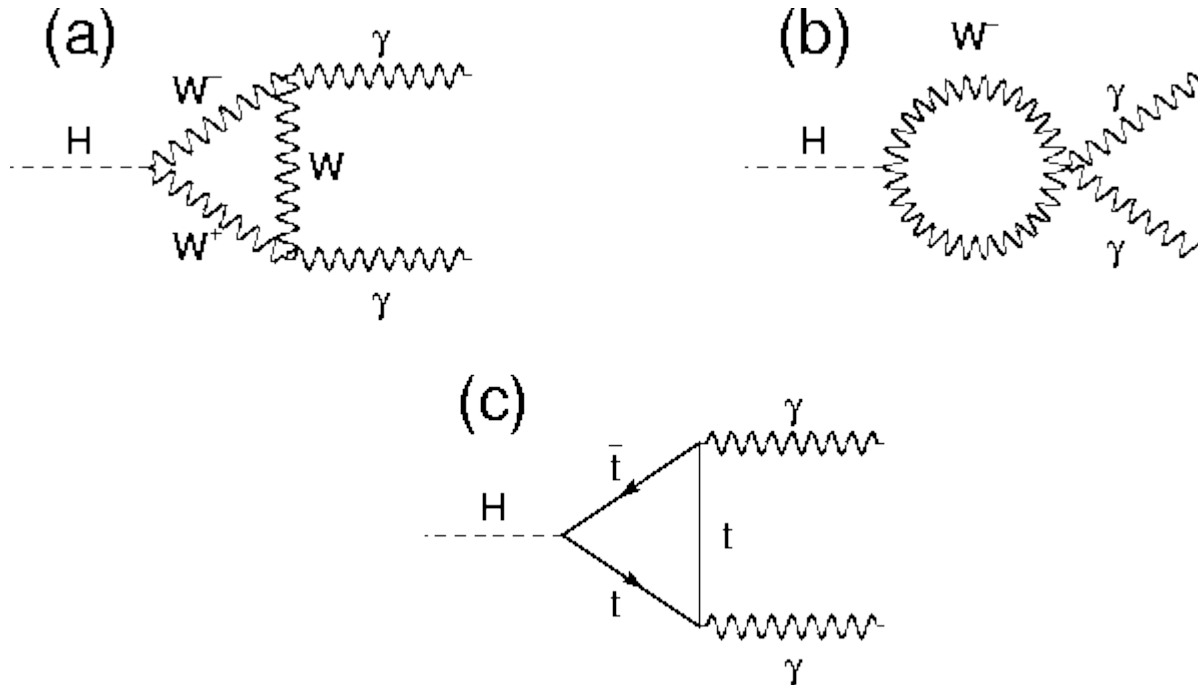



CMS Experiment at the LHC, CERN
Data recorded: 2012-May-13 20:08:14.621490 GMT
Run/Event: 194108 / 564224000

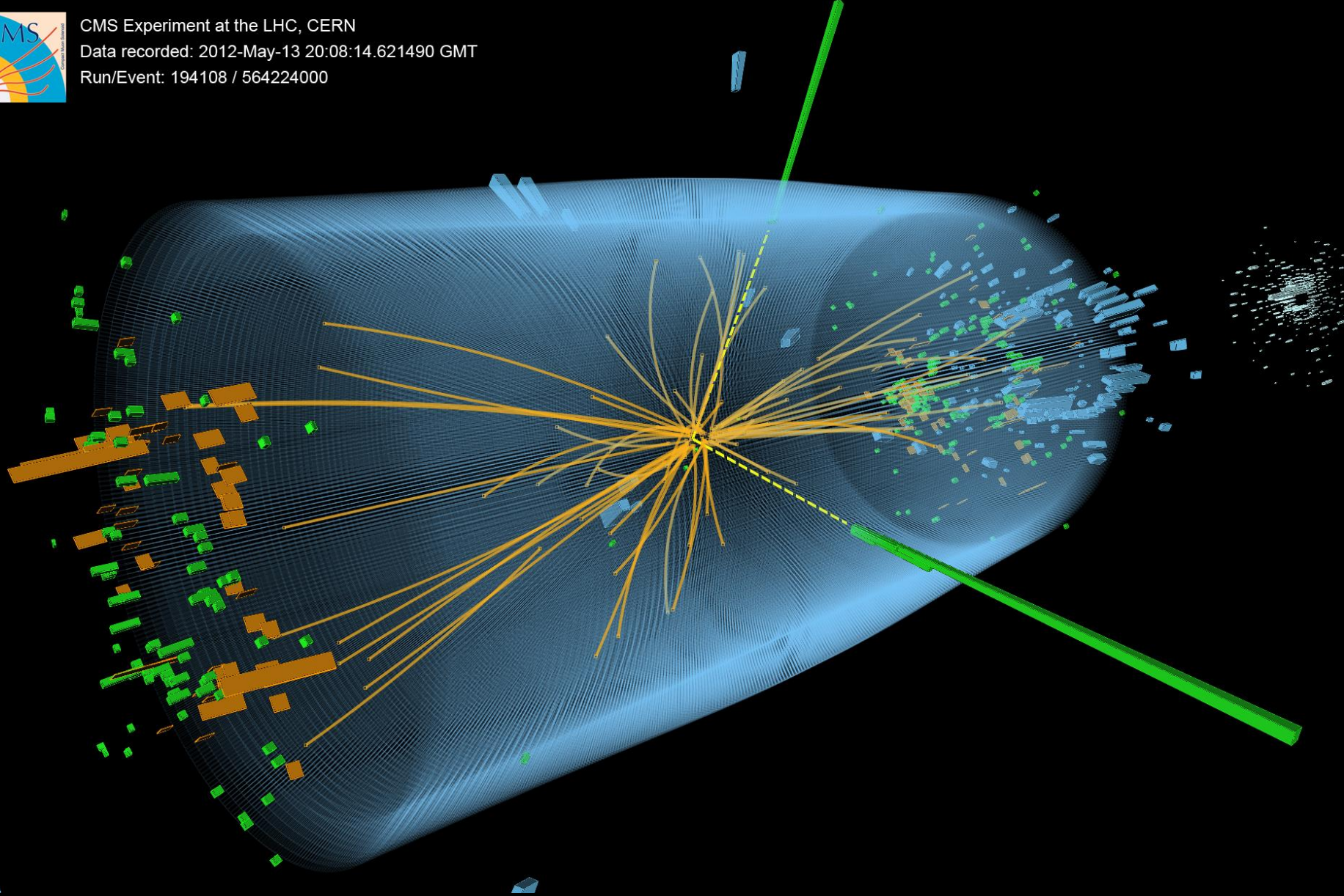

$H \rightarrow \gamma\gamma$ candidate event (CMS)

$H \rightarrow \gamma\gamma$

Clean discovery channels for Higgs, allowing precise mass determination

ATLAS arXiv:1207.7214, CMS arXiv:1207.7235, both submitted on Aug 1st, 2012 to PLB

Benefit from excellent energy resolution and photon identification capabilities of ATLAS/CMS

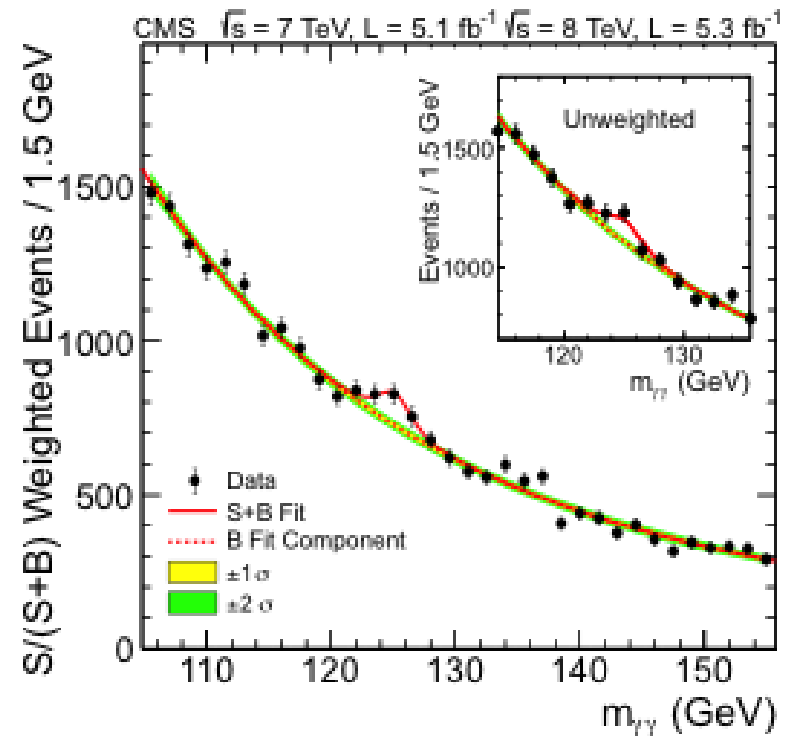
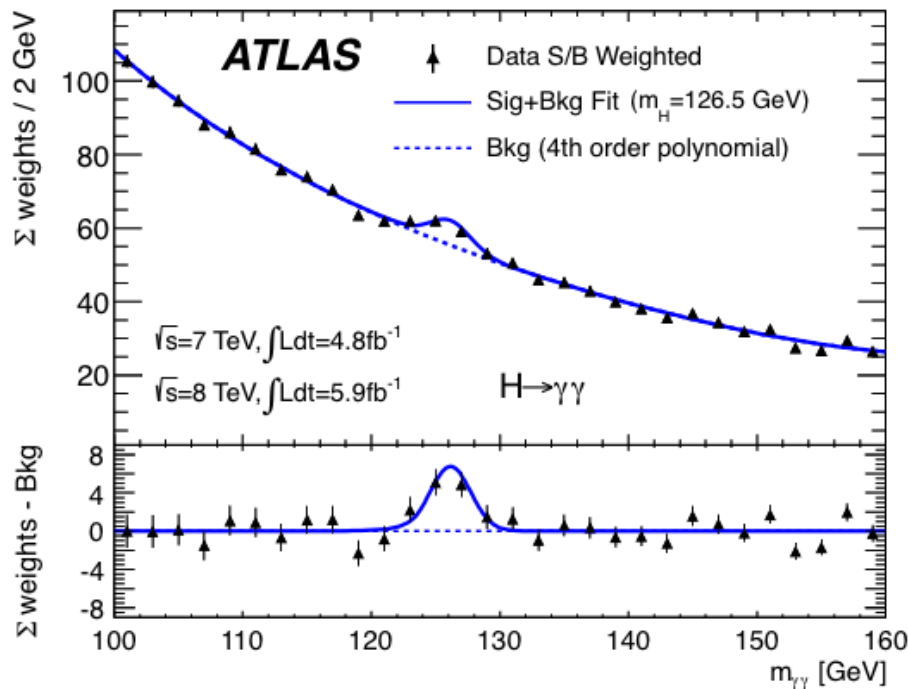

Both experiments classify events according to resolution and topology in ML fit

Maximum excess of 4.5σ (4.1σ) seen by ATLAS (CMS) at 126.5 (125) GeV

A look at the details

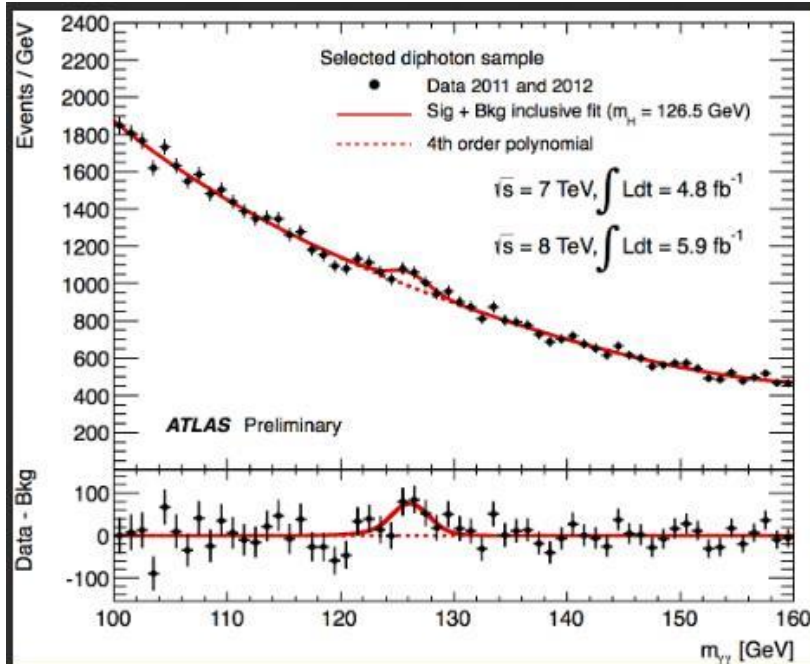

Total after selections: 59059 events

$m_{\gamma\gamma}$ spectrum fit, for each category, with Crystal Ball + Gaussian for signal plus background model optimised (with MC) to minimize biases
 Max deviation of background model from expected background distribution taken as systematic uncertainty

Main systematic uncertainties

Signal yield	
Theory	~ 20%
Photon efficiency	~ 10%
Background model	~ 10%
Categories migration	
Higgs p_T modeling	up to ~ 10%
Conv/unconv γ	up to ~ 6%
Jet E-scale	up to 20% (2j/VBF)
Underlying event	up to 30% (2j/VBF)
$H \rightarrow \gamma\gamma$ mass resolution	~ 14%
Photon E-scale	~ 0.6%

$$H \rightarrow ZZ^*$$

One of the best performing channels
in the whole mass range ...

... but extremely demanding channel for
selection, requiring the highest possible
efficiencies (lepton Reco/ID/Isolation).

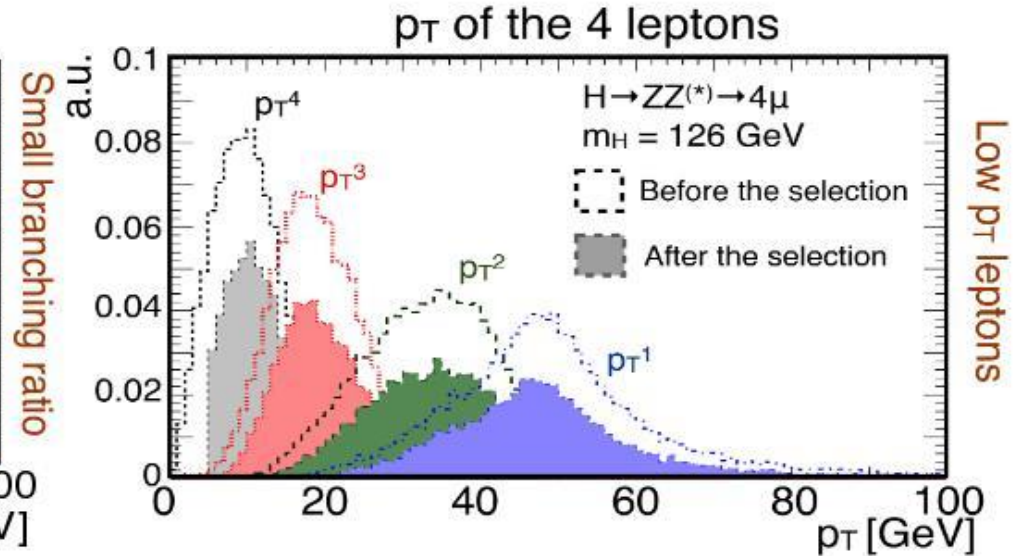
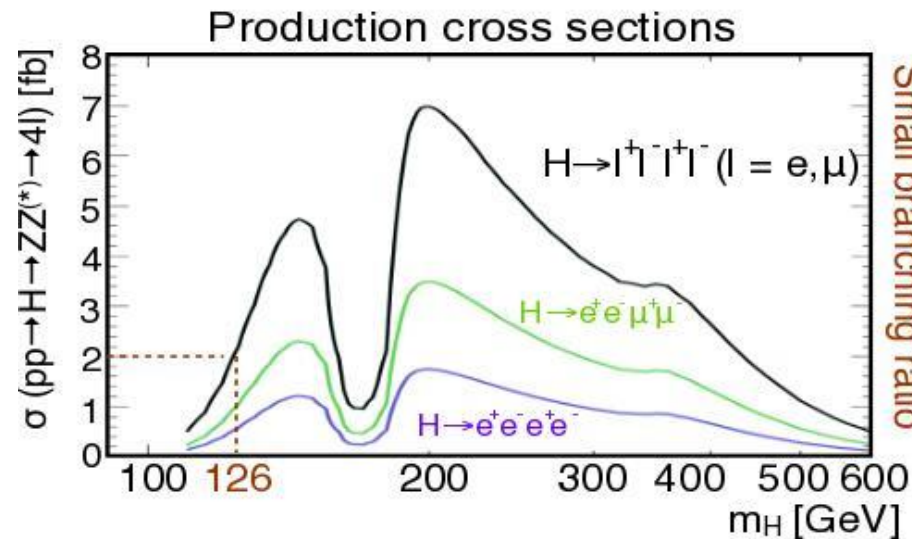



CMS Experiment at the LHC, CERN
Data recorded: 2012-May-27 23:35:47.271030 GMT
Run/Event: 195099 / 137440354

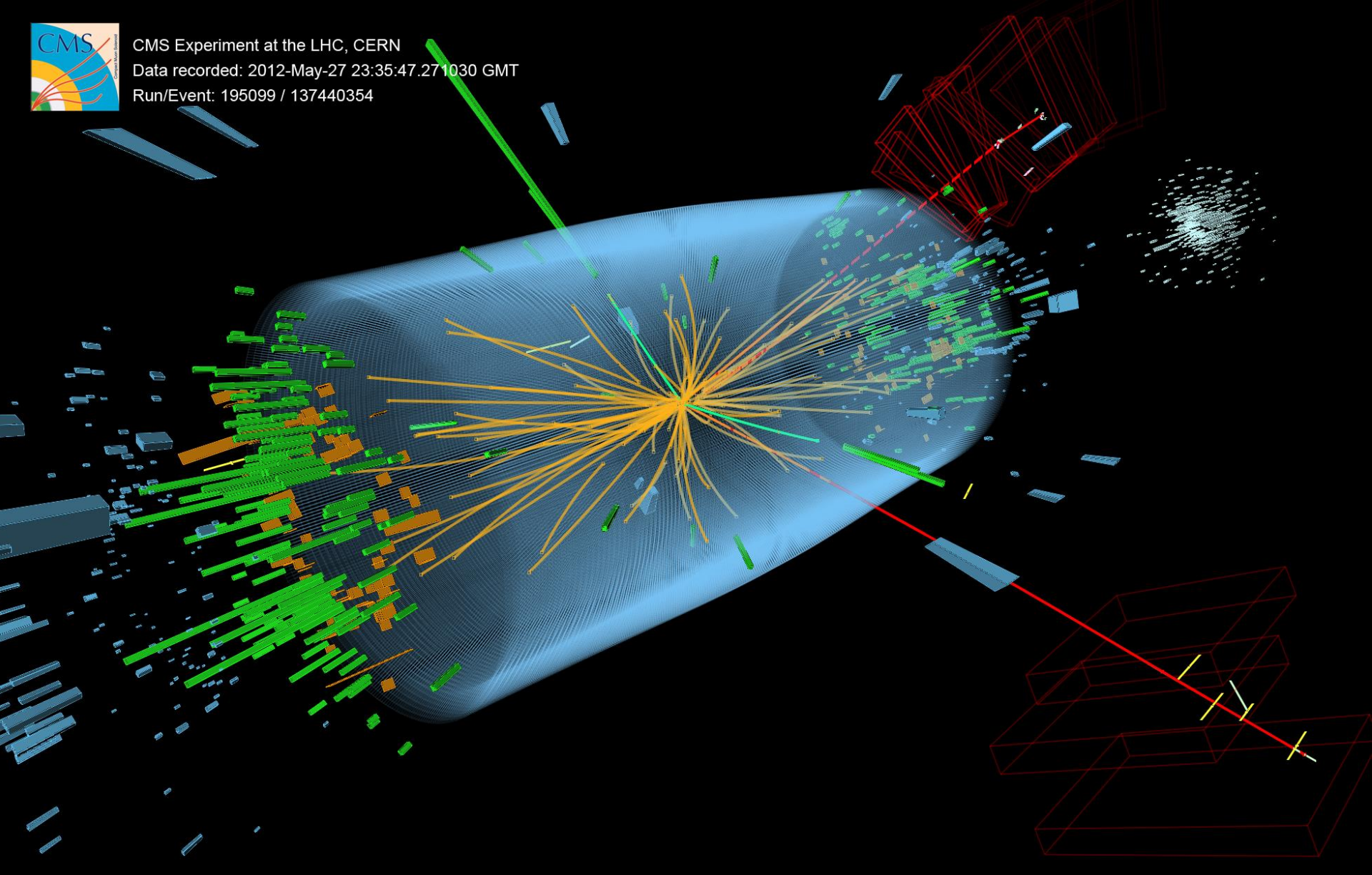

$H \rightarrow 2e2\mu$ candidate event (CMS)

$H \rightarrow ZZ^{(*)} \rightarrow 2(e, \mu) + 2(e, \mu)$

Clean discovery channels for Higgs, allowing precise mass determination

Benefit from excellent energy/momentum resolution and identification capabilities at ATLAS/CMS

ATLAS arXiv:1207.7214, CMS arXiv:1207.7235, both submitted on Aug 1st, 2012 to PLB

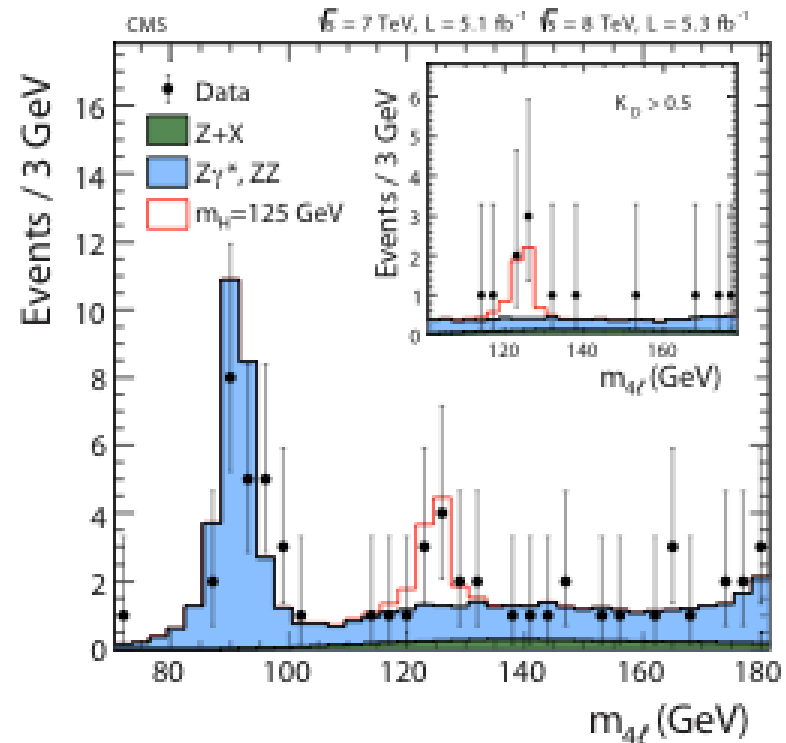
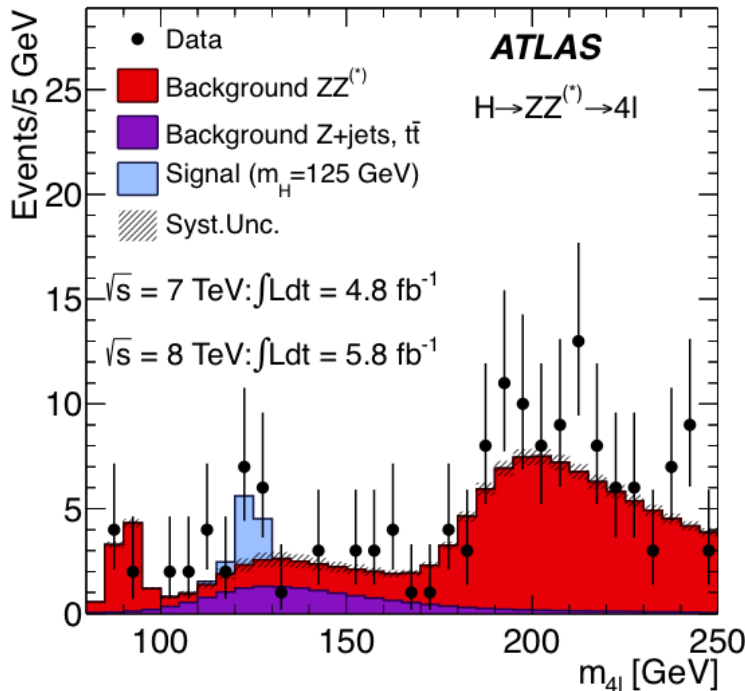

Order one S/B ratio. Maximum excess of 3.6σ (3.2σ) seen by ATLAS (CMS) at 125 (125.6) GeV

$H \rightarrow ZZ^{(*)} \rightarrow 2(e, \mu) + 2(e, \mu)$

Clean discovery channels for Higgs, allowing precise mass determination

Benefit from excellent energy/momentum resolution and identification capabilities at ATLAS/CMS

ATLAS arXiv:1207.7214, CMS arXiv:1207.7235, both submitted on Aug 1st, 2012 to PLB

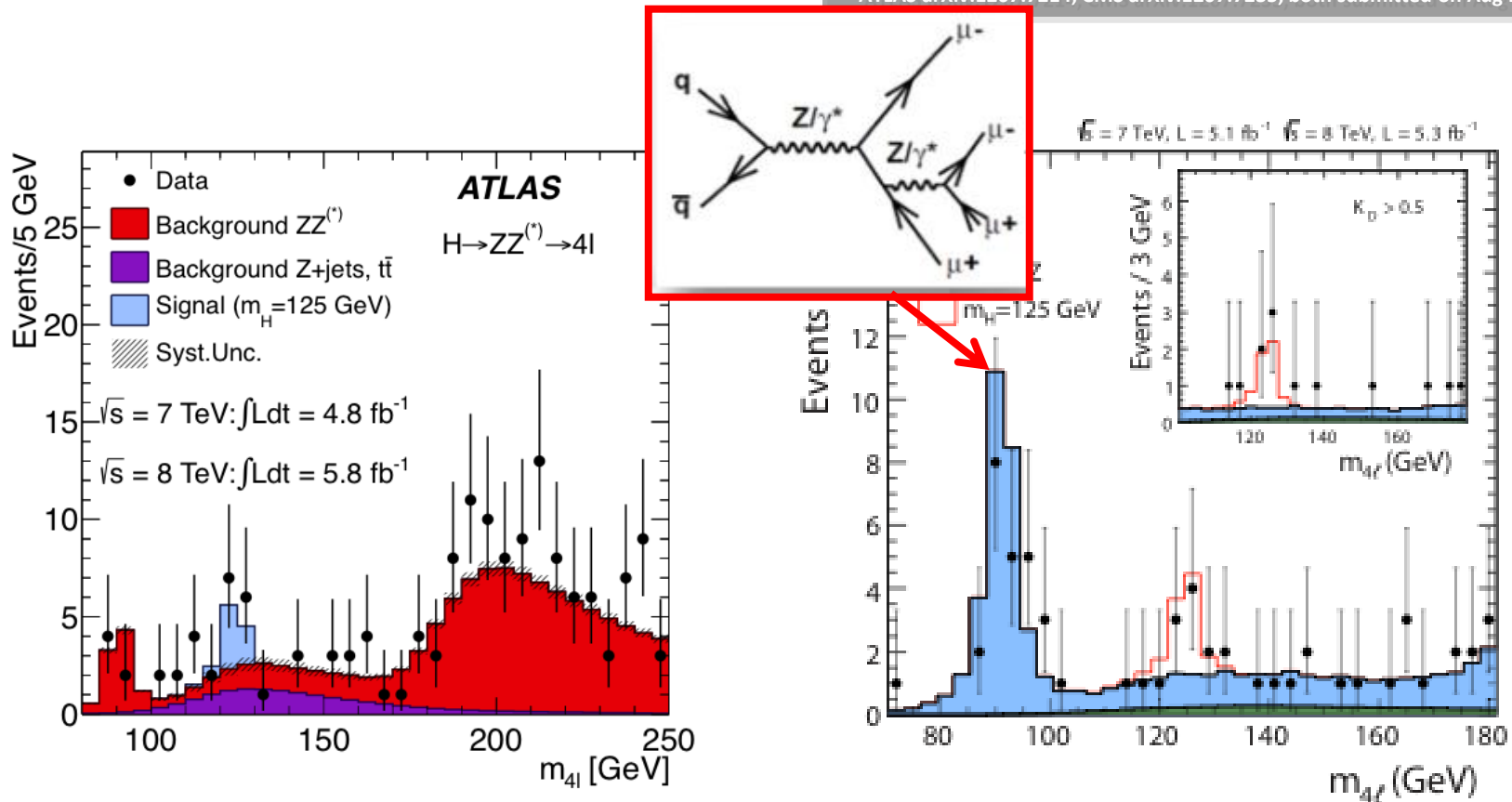

Order one S/B ratio. Maximum excess of 3.6σ (3.2σ) seen by ATLAS (CMS) at 125 (125.6) GeV

ATLAS combined July 2012

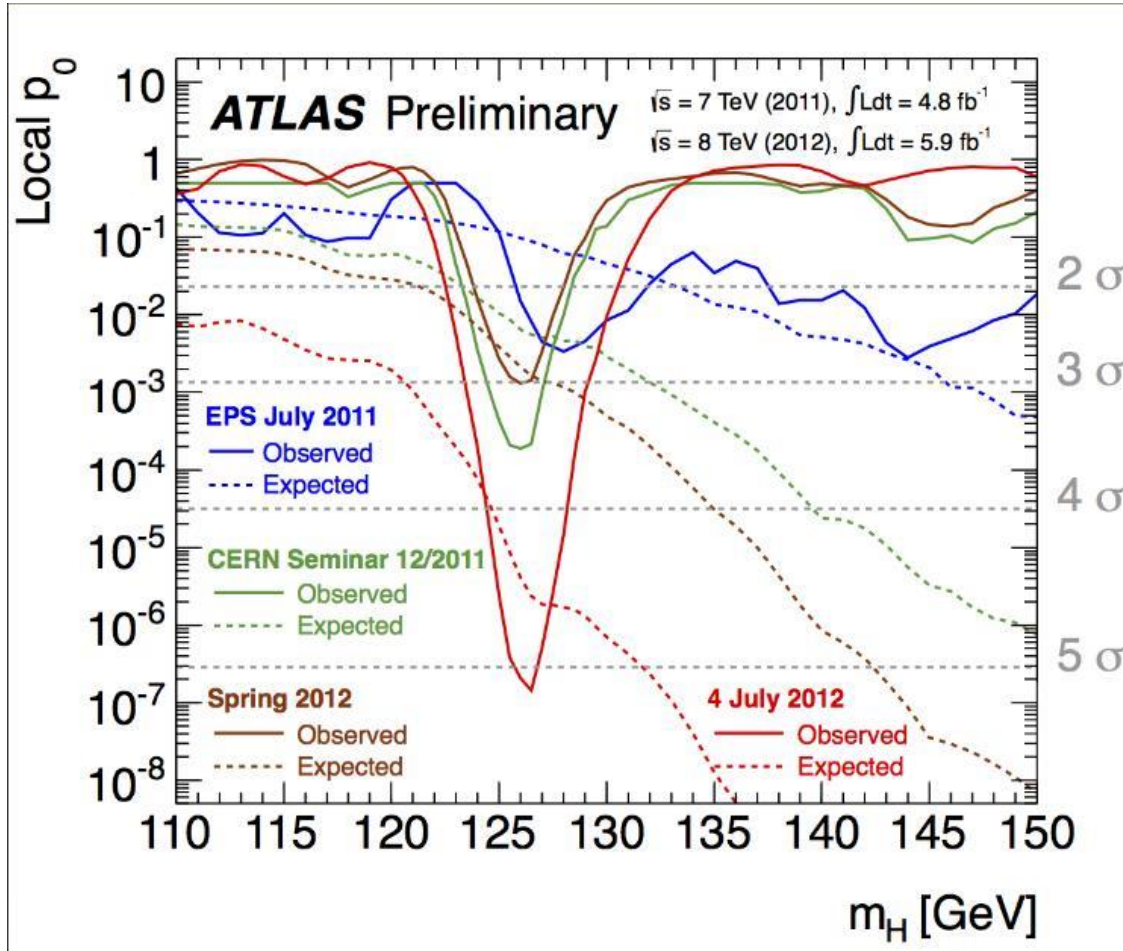

Max excess

@ 126.5 GeV

Local significance:

5.0 sigma

p-value: 3×10^{-7}

Global significance:

4.1-4.3 sigma

I.e. an "observation"
not discovery

CMS combined July 2012

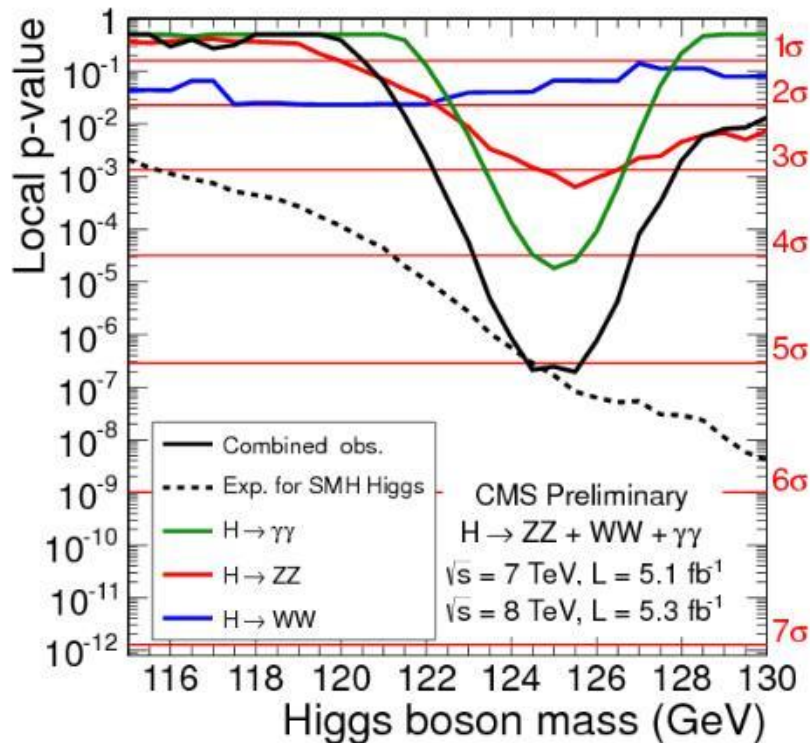

adding high sensitivity, but
low mass resolution WW

comb. significance: **5.1 σ**

expected significance
for SM Higgs: **5.2 σ**

Global significance similar to ATLAS's, i.e. observation only

Other channels

- $H \rightarrow WW \rightarrow l\nu l\nu$

Less clean, little mass sensitivity but abundant

Result:

roughly 2σ /experiment

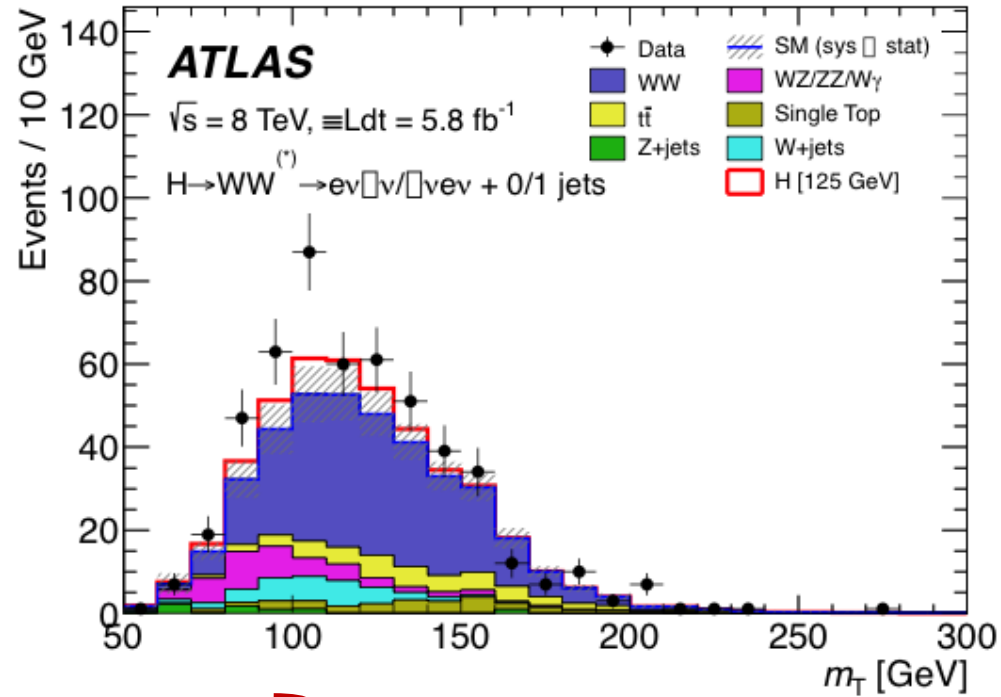

- Associated production WH, ZH

- $H \rightarrow \tau\tau$

} Little sensitivity in first analysis

H \rightarrow WW candidate

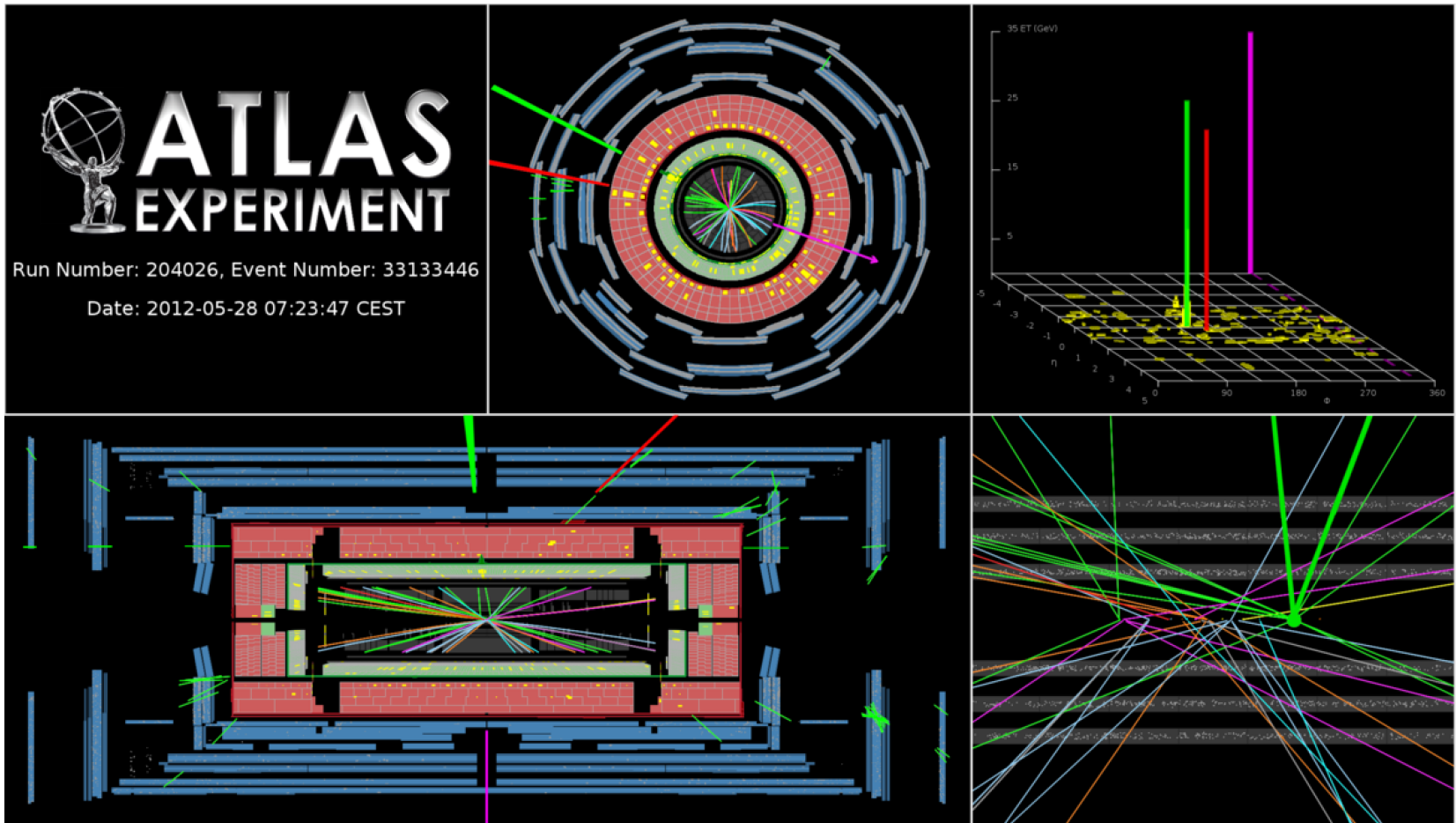

CMS combined July 2012

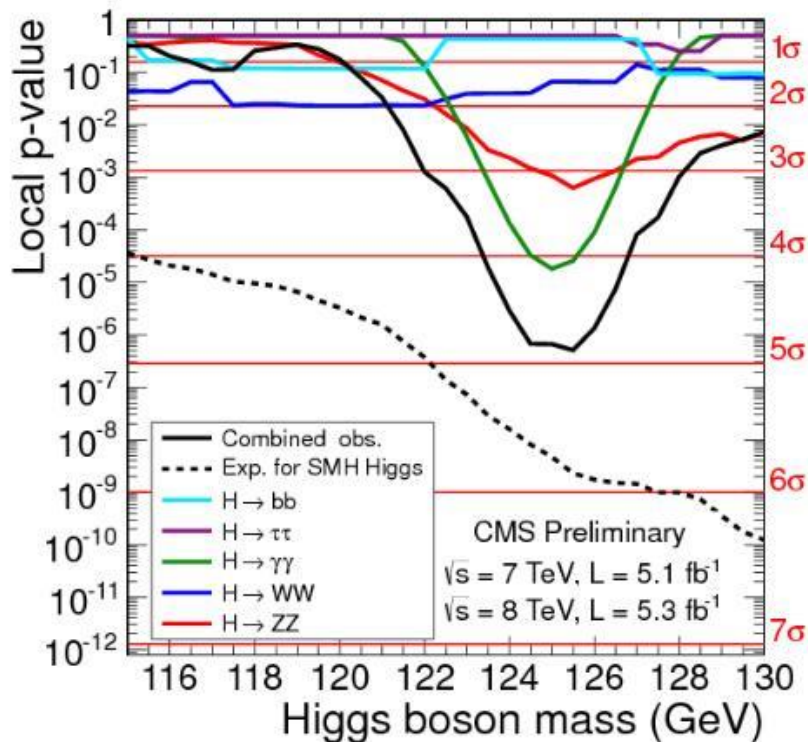

- all channels together:

comb. significance: **4.9 σ**

- expected significance

for SM Higgs: **5.9 σ**

Some times adding more channels means a smaller observation!

Combining all the channels

ATLAS: $m_H = (126.0 \pm 0.4 \pm 0.4) \text{ GeV}$

CMS: $m_H = (125.3 \pm 0.4 \pm 0.5) \text{ GeV}$

$$m_H \sim (125.7 \pm 0.4) \text{ GeV}$$

Private average

What can we conclude from this discovery

Recall: light Higgs was predicted from SM fit to precision measurements

Discovery of light Higgs boson is a *huge success* of the Standard Model

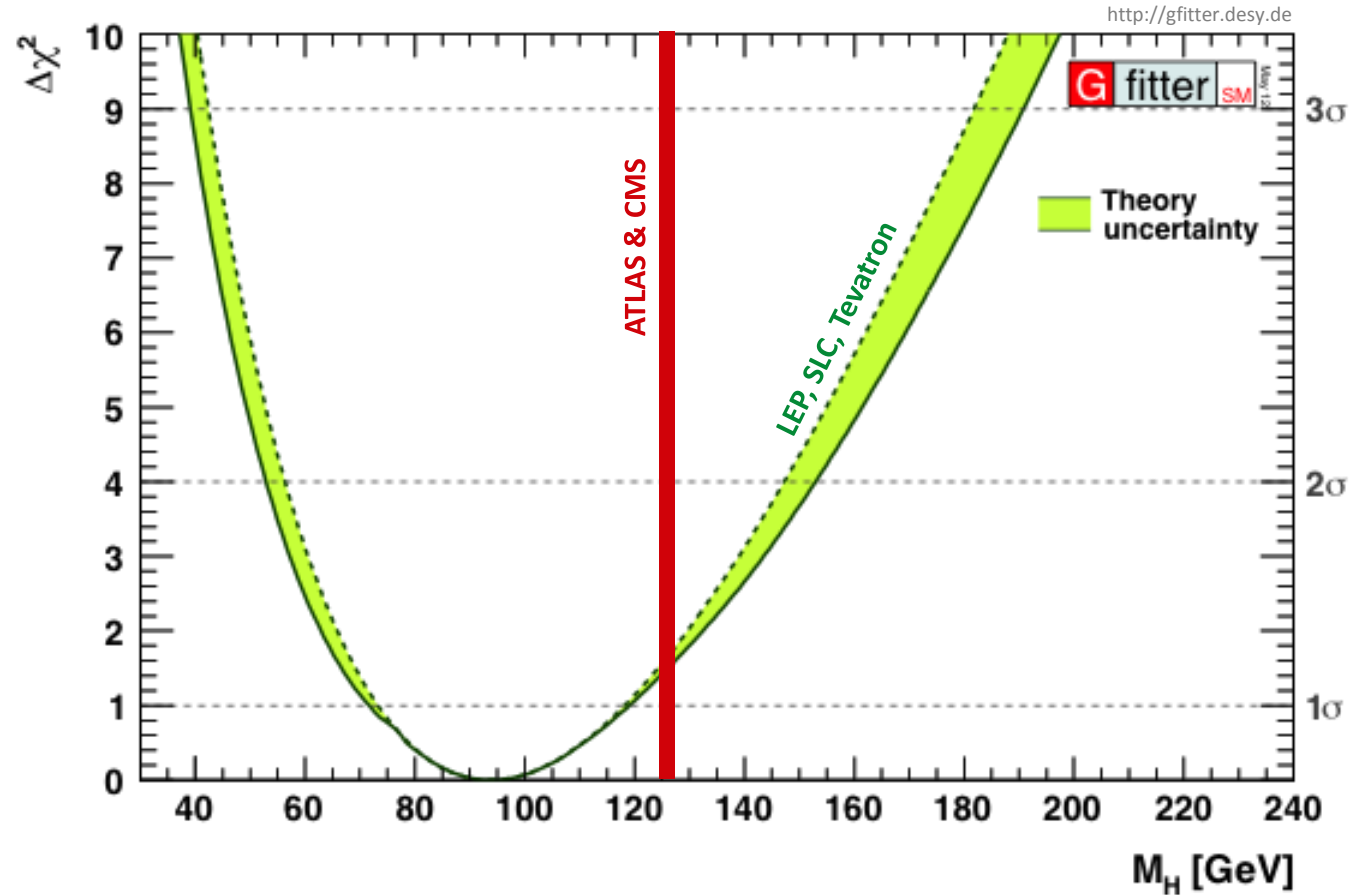
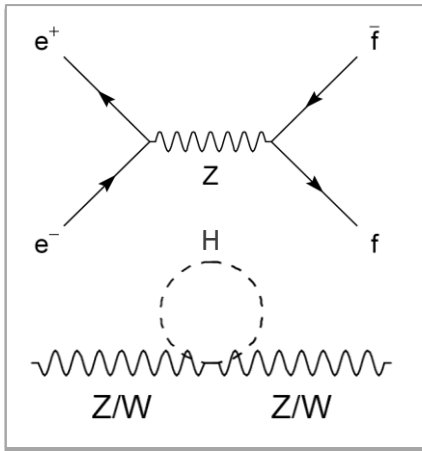

What can we conclude from this discovery

Is the electroweak vacuum stable or metastable (if SM holds) ?

Barely stable ?

But: prediction of the stability bound suffers from theoretical uncertainties ...

Newest full NNLO result moves up stability bound at Planck mass by +0.8 GeV and reduces uncertainty

→ **barely stable or metastable, but certainly the Higgs self coupling would become very weak at M_{Pl}**

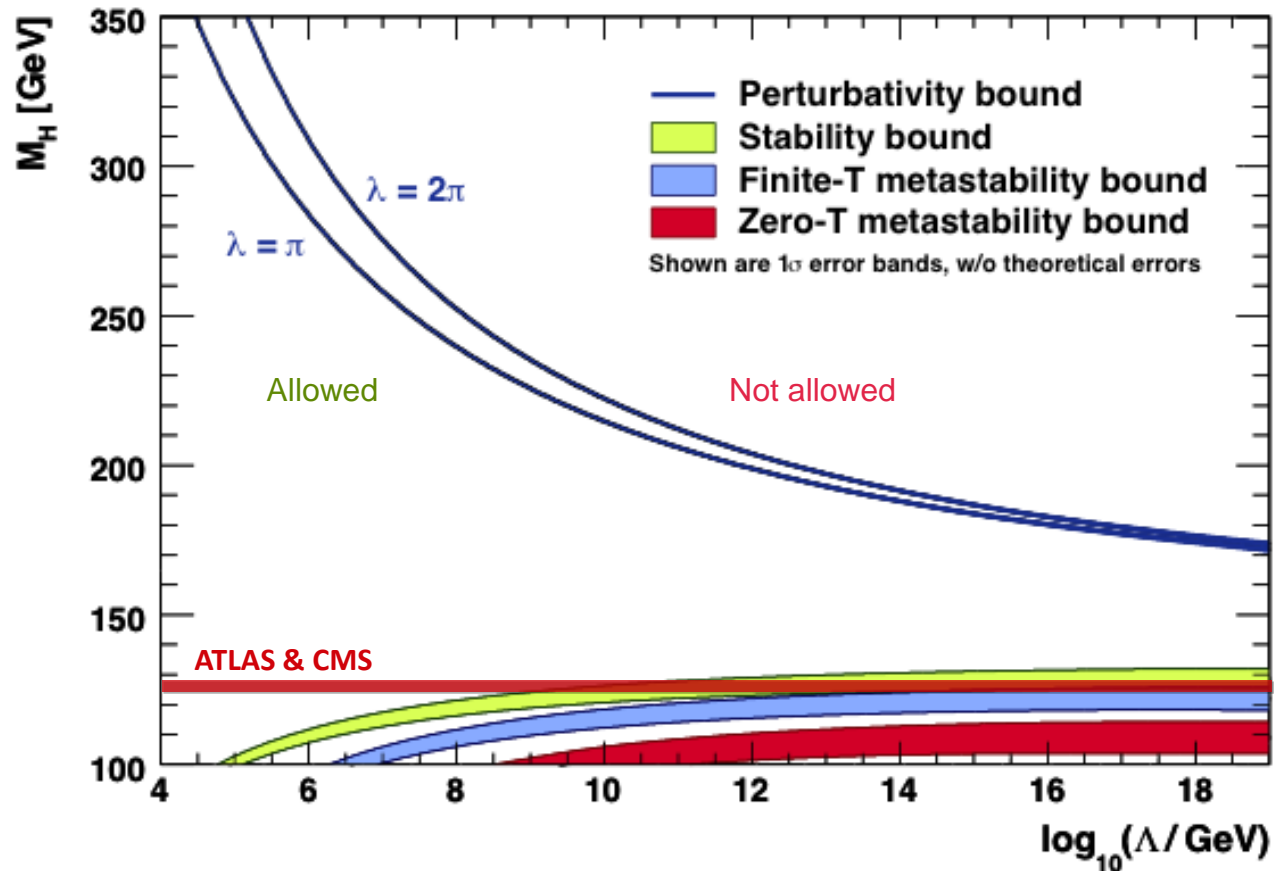

Ellis et al, arXiv:0906.0954

Current status

What have we learned about the Higgs boson and the Higgs mechanism since then?

Lots of measurements in more channels

ATLAS Prelim.

$m_H = 125.36$ GeV

— $\sigma(\text{stat.})$ Total uncertainty
 — $\sigma(\text{sys inc. theory})$ $\pm 1\sigma$ on μ

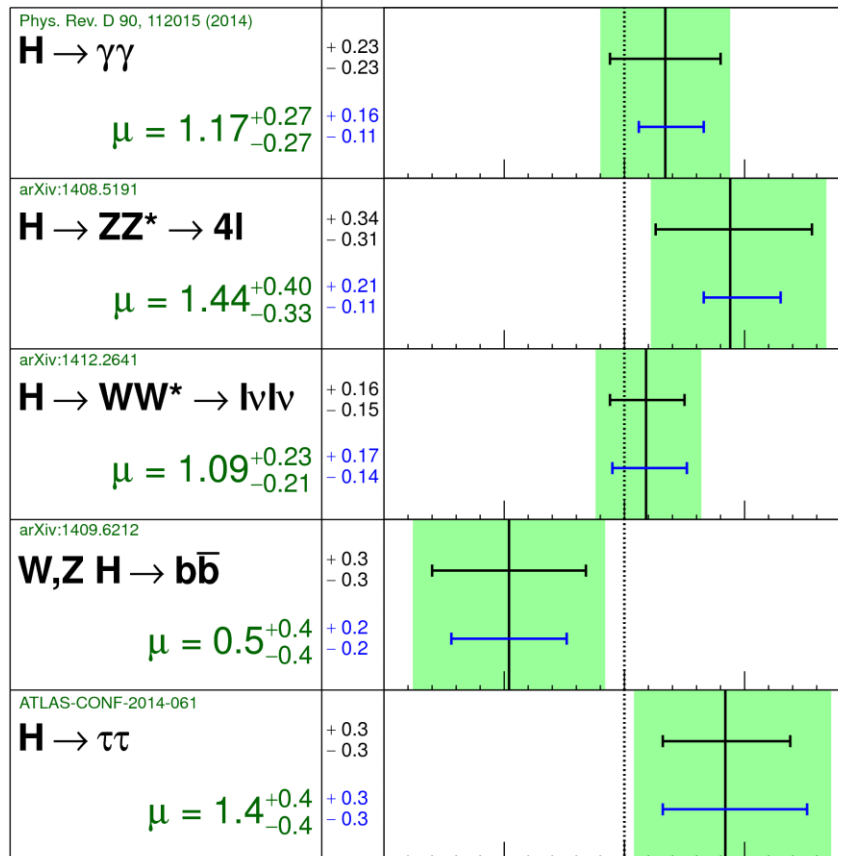

$\sqrt{s} = 7$ TeV $\int L dt = 4.5\text{-}4.7$ fb $^{-1}$

$\sqrt{s} = 8$ TeV $\int L dt = 20.3$ fb $^{-1}$

Signal strength (μ)

released 12.01.2015

19.7 fb $^{-1}$ (8 TeV) + 5.1 fb $^{-1}$ (7 TeV)

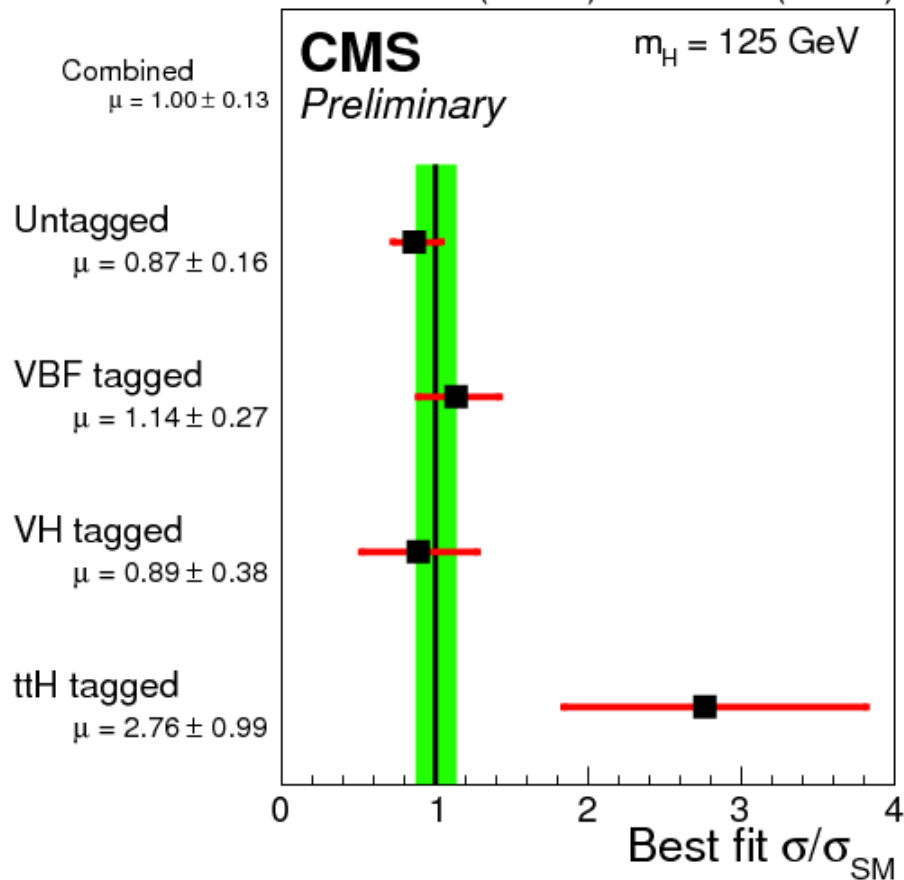

Higgs and Flavour Physics

125.5 GeV Higgs boson – SM properties

[LHCPhysics/CrossSections]

Cross sections and branching fractions precisely predicted ($m_H = 125.5$ GeV)

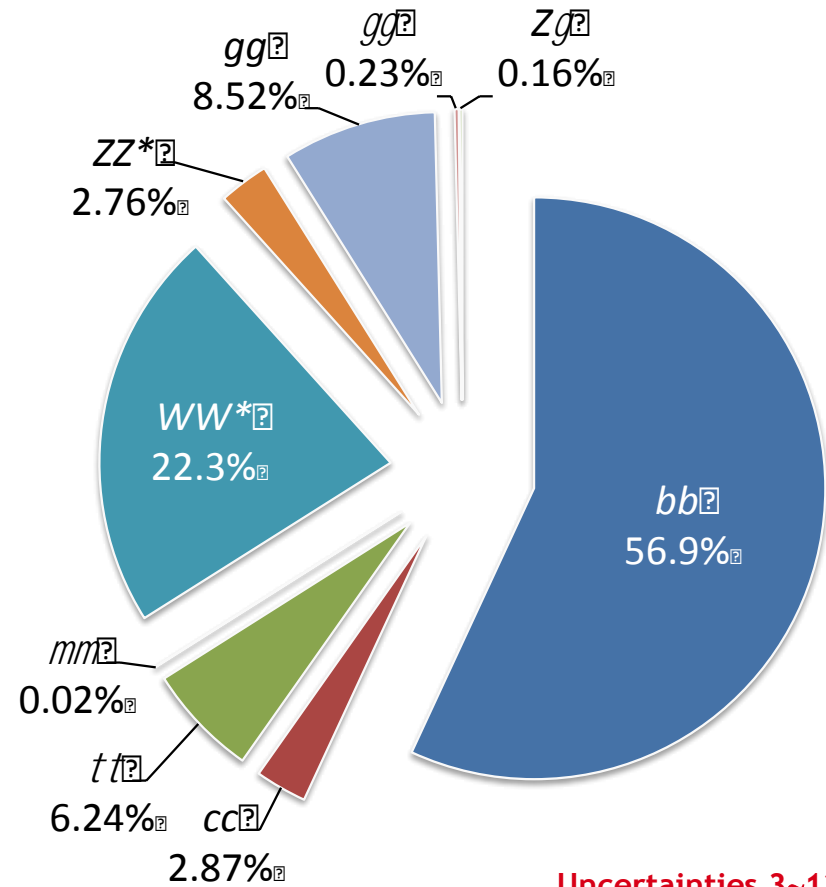
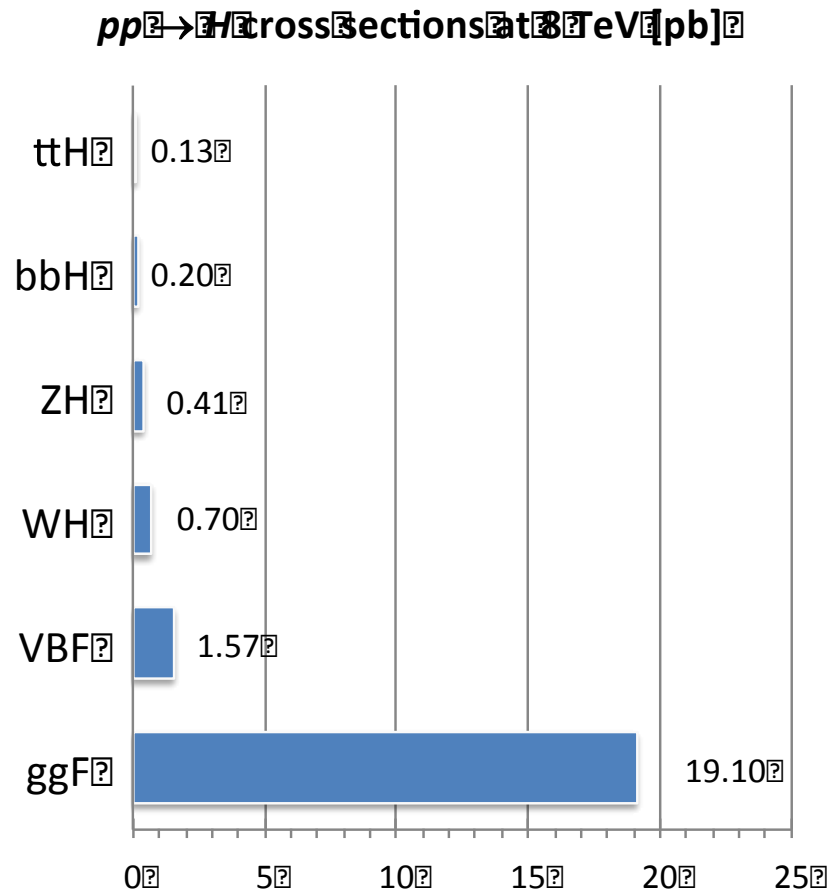

Higgs mass

SM predictions can (so far) live without a precision m_H measurement, but as experimentalists we want to do the best possible job

- Recent final Run-1 result by ATLAS after improvement of detector material description and recalibration using all SM candles (Z , W , J/ψ , Y)

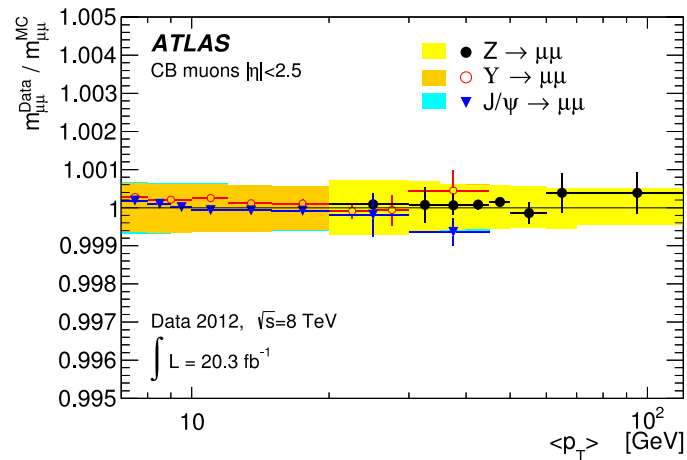

Table 5: Summary of Higgs boson mass measurements.

Channel	Mass measurement [GeV]
$H \rightarrow \gamma\gamma$	125.98 ± 0.42 (stat) ± 0.28 (syst) = 125.98 ± 0.50
$H \rightarrow ZZ^* \rightarrow 4\ell$	124.51 ± 0.52 (stat) ± 0.06 (syst) = 124.51 ± 0.52
Combined	125.36 ± 0.37 (stat) ± 0.18 (syst) = 125.36 ± 0.41

- Compatible in value and uncertainty with CMS result from 4-lepton channel:

CMS: 1312.5353]

$$125.6 \pm 0.4_{\text{stat}} \pm 0.2_{\text{syst}} \text{ GeV}$$

Higgs spin and CP

Higgs boson appears to be SM-like: $J^P = 0^+$

[CMS: 1312.5353]

From most powerful spin/CP analyser: $H \rightarrow 4\text{-lepton}$

- 0^- excluded at 3.6σ ; CP-odd fraction in decay amplitude: $f_{a3} < 0.51$ (95% CL)
- Spin-1, 2 hypotheses excluded $\gg 95\%$ CL

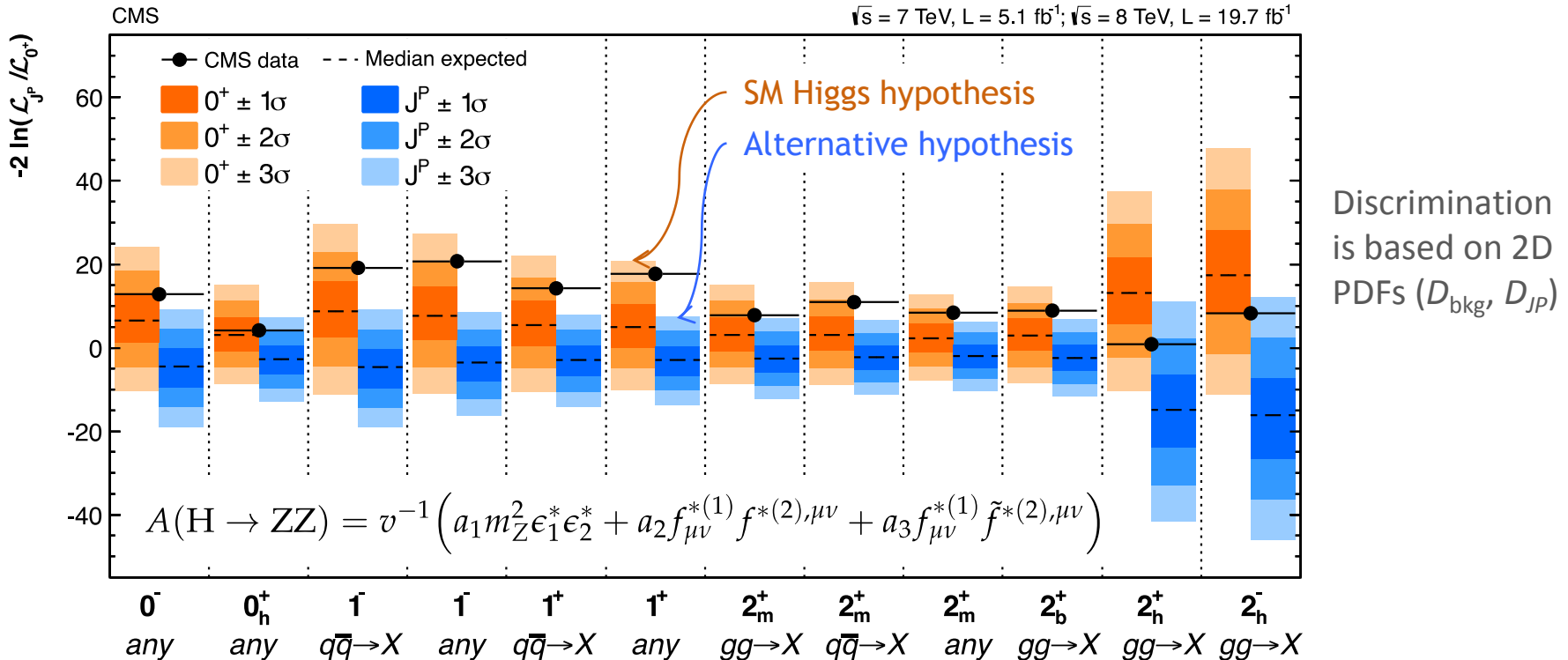

Higgs and Flavour Physics

SM Higgs to fermions — $\tau\tau$

[ATLAS-CONF-2013-108, CMS: 1401.5041]

Higgs to fermion analyses all very challenging (or too low BR)

- Di-tau reconstructed in all lep/had topologies and jets: 0, 1 (boosted or not), 2 (VBF, VH)
- BDT-based tau identification, Higgs discrimination based on $m_{\tau\tau}$
- Likelihood-based calculator to estimate $m_{\tau\tau}$, $\sigma(m_{\tau\tau}) = 13\% \sim 20\%$, best for boosted τ
- Background dominated by $Z \rightarrow \tau\tau$ (use “ τ embedded” $Z \rightarrow \mu\mu$), also top and fakes important

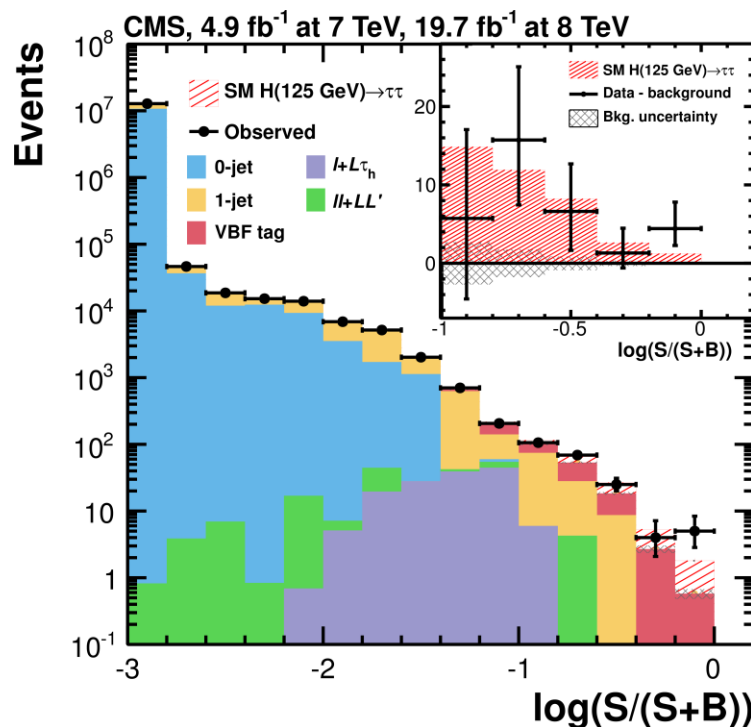
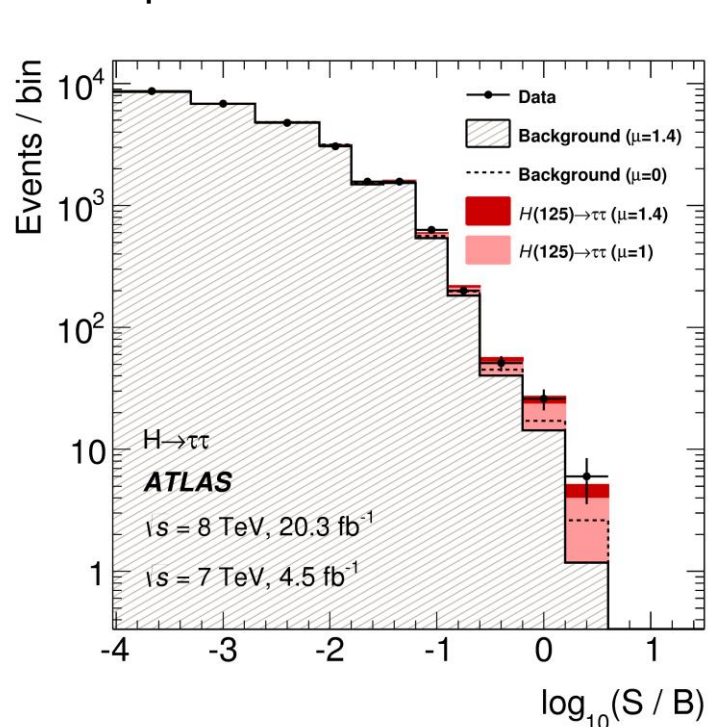

At 125 GeV:

ATLAS (8 TeV):
 $\mu = 1.4^{+0.5}_{-0.4}$
 (4.1 σ)

CMS (7+8 TeV):
 $\mu = 0.78 \pm 0.27$
 (3.4 σ)

Higgs and Flavour Physics

SM Higgs to fermions – $\mu\mu$

[ATLAS-CONF-2013-010, CMS-PAS-HIG-13-007]

Low branching fraction (ten times smaller than $\gamma\gamma$), mainly data-driven fit akin to $H \rightarrow \gamma\gamma$

- Slight complication due to sum of dominant DY and sub-dominant tt , WW backgrounds
- Separation of jet (gluon fusion, VBF), and S/B (central, non-central) categories

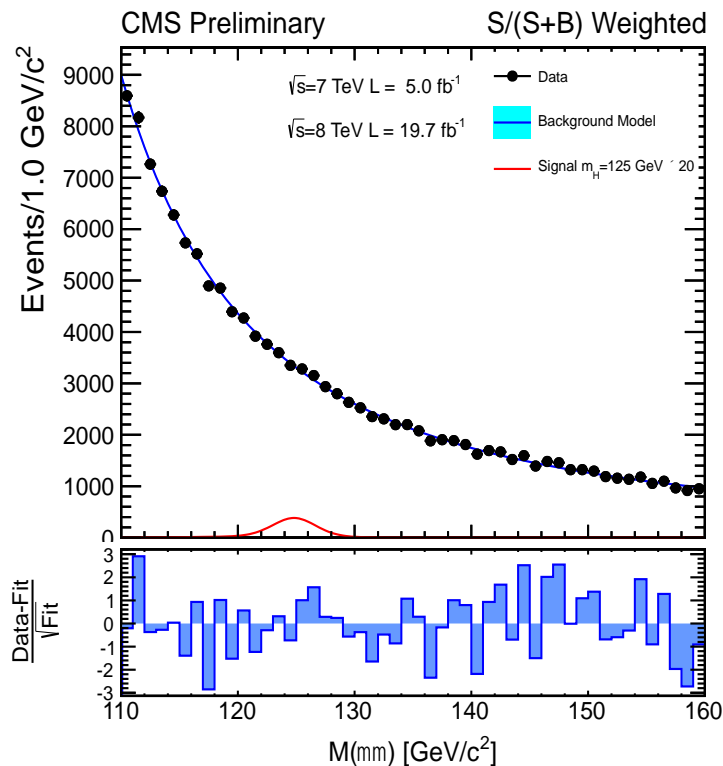
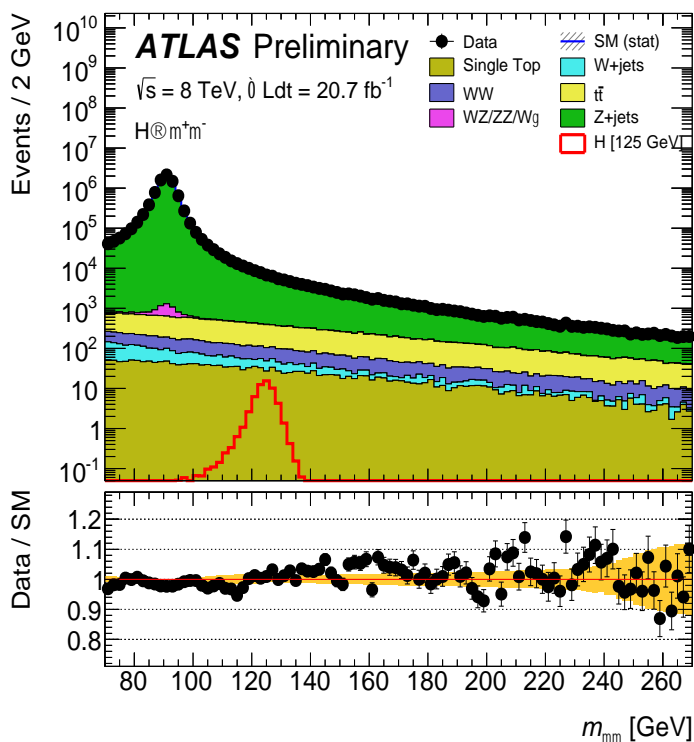

At 125 GeV:

ATLAS (8 TeV):
 $\mu < 9.8$ (8.2 exp.)
 (95% CL)

CMS (7+8 TeV):
 $\mu < 7.4$ (5.1 exp.)
 (95% CL)

Higgs bottom line for Run 1 (7 + 8 TeV)

[CMS-PAS-HIG-13-005]

Great measurements —
the overall picture is as
expected in the SM

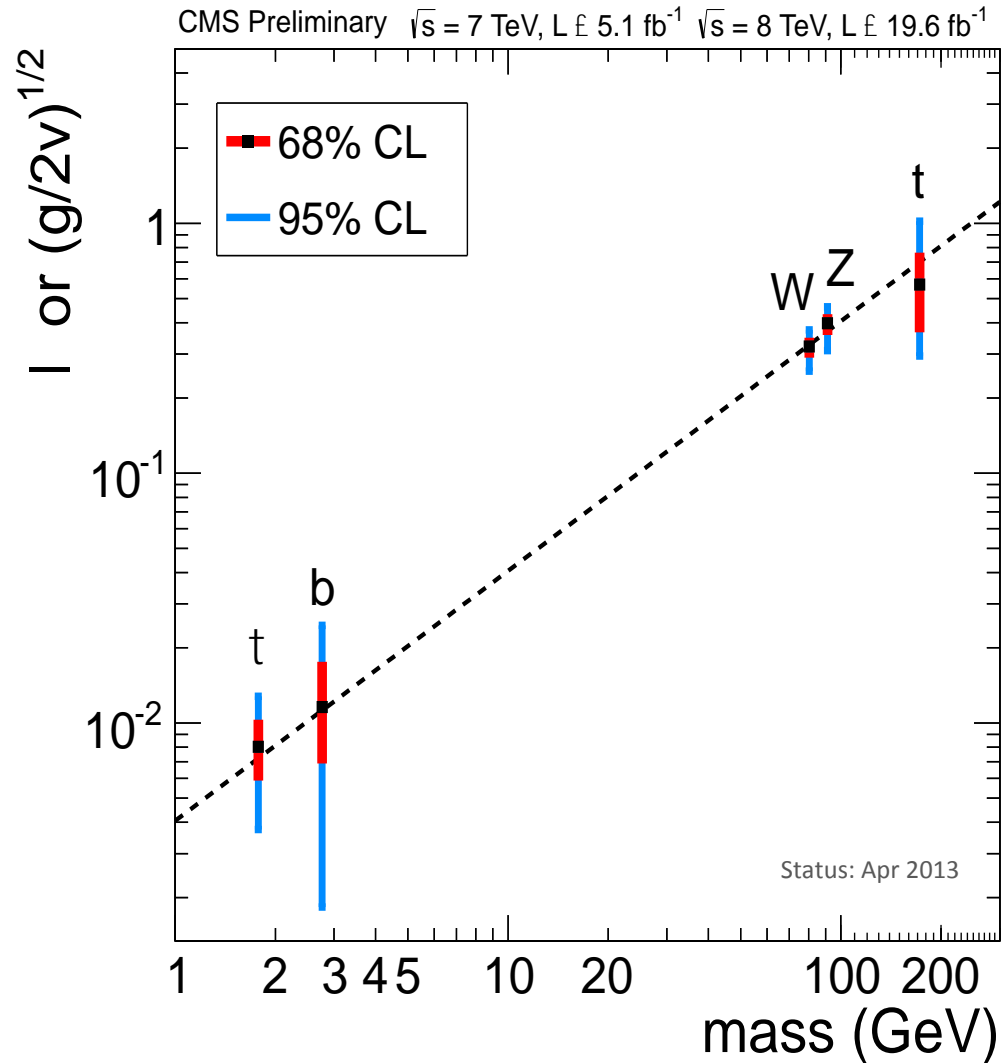

And 13 TeV?

Unfortunately not much to say yet –
CMS analysis still “blinded”
ATLAS analysis barely sensitive

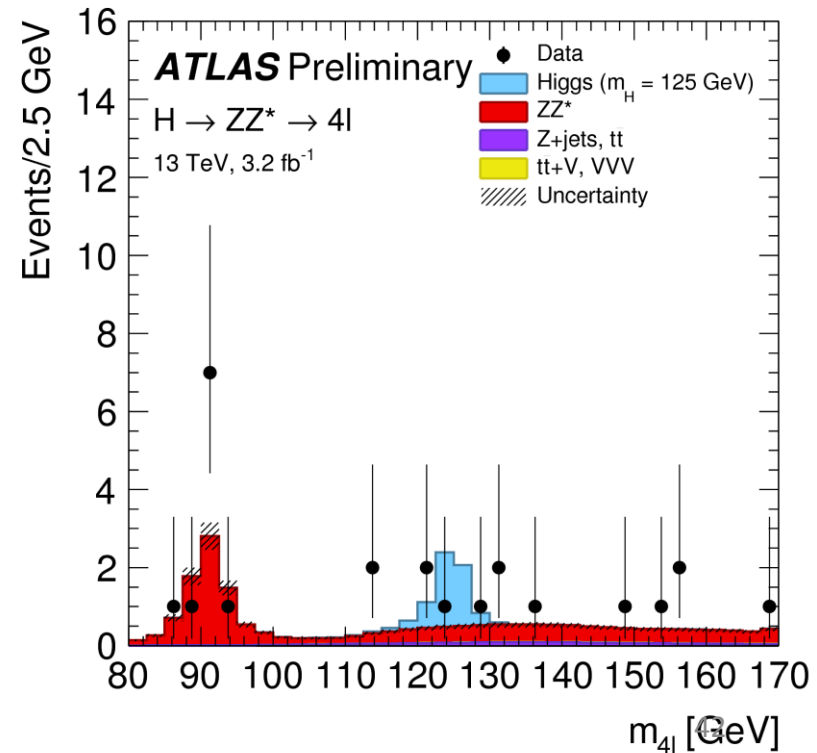
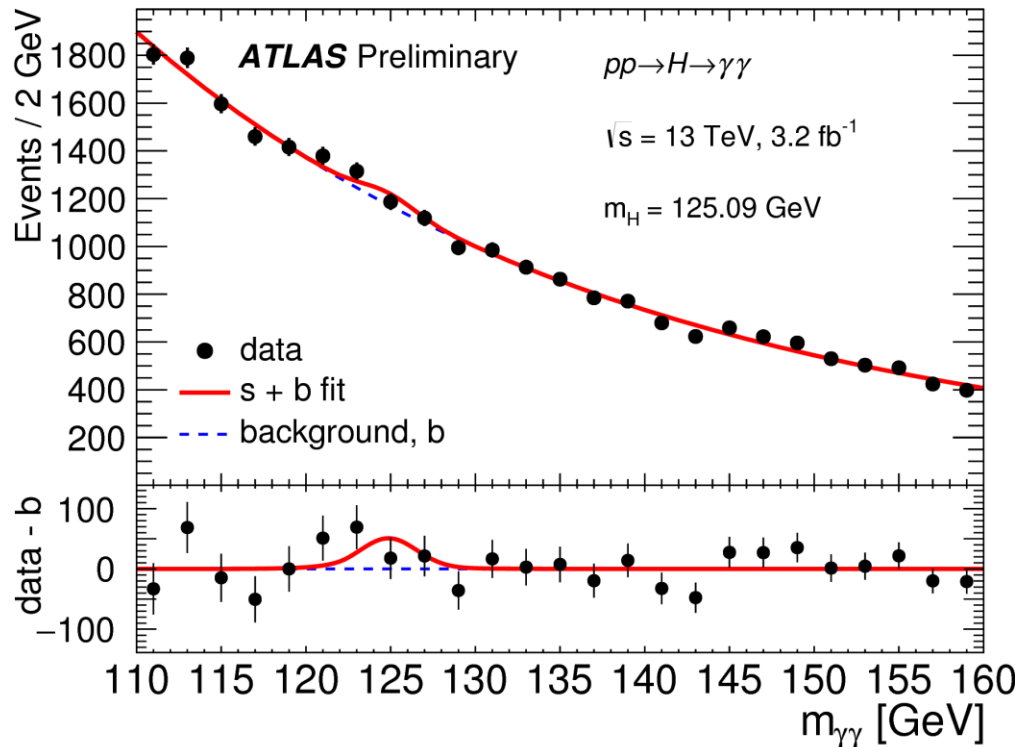

Summary/outlook

- The Higgs field is fundamental for the Standard model
 - *And our Universe!*
- Discovery of the boson took a lot of effort
 - *Needed all parts of the detector, all the "usual" objects, and with high precision*
- Studying the Higgs boson is another window to find physics beyond the Standard Model
 - *It "saves" the SM but introduces new problems*
 - *More next time*