

### Input connectors

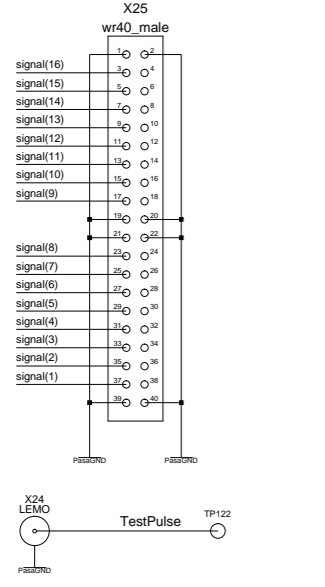

### Reference buffers

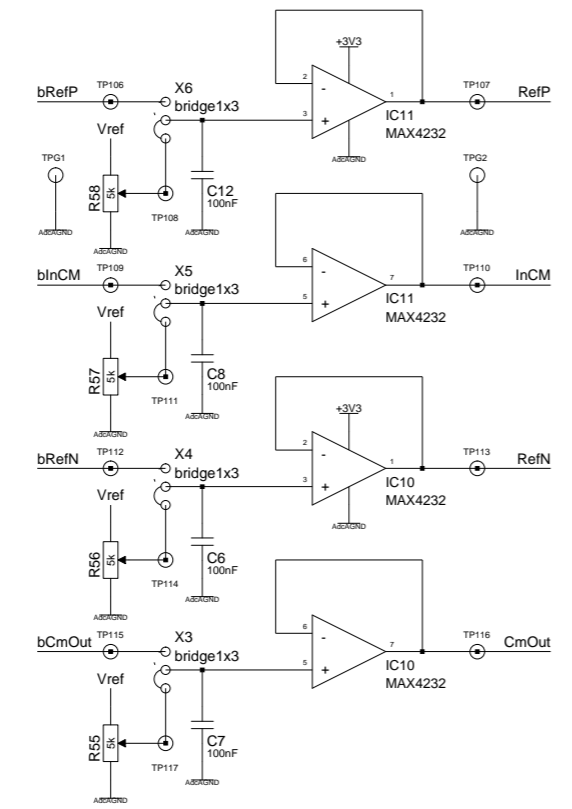

### MCM control & communication

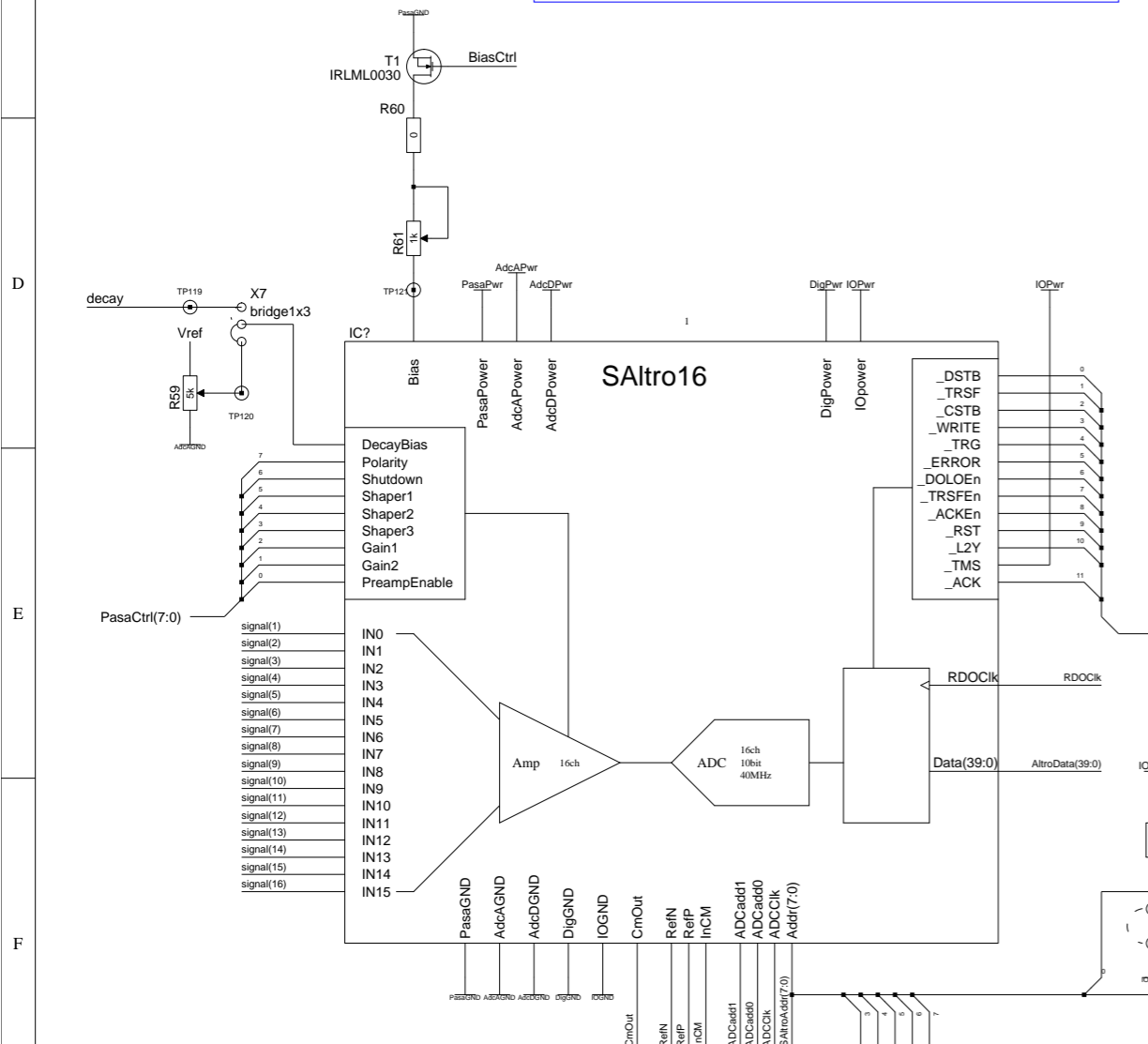
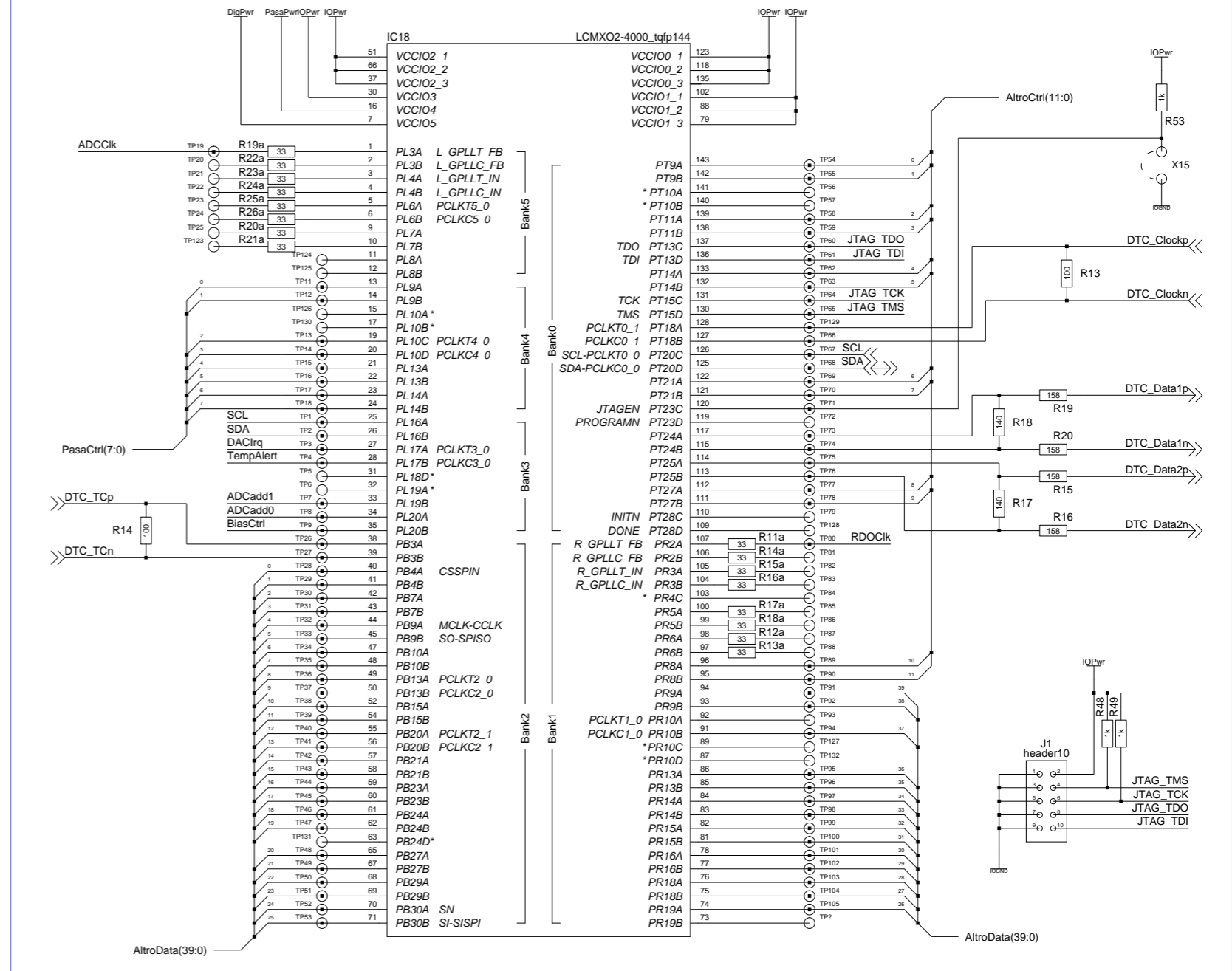

### Reference generator

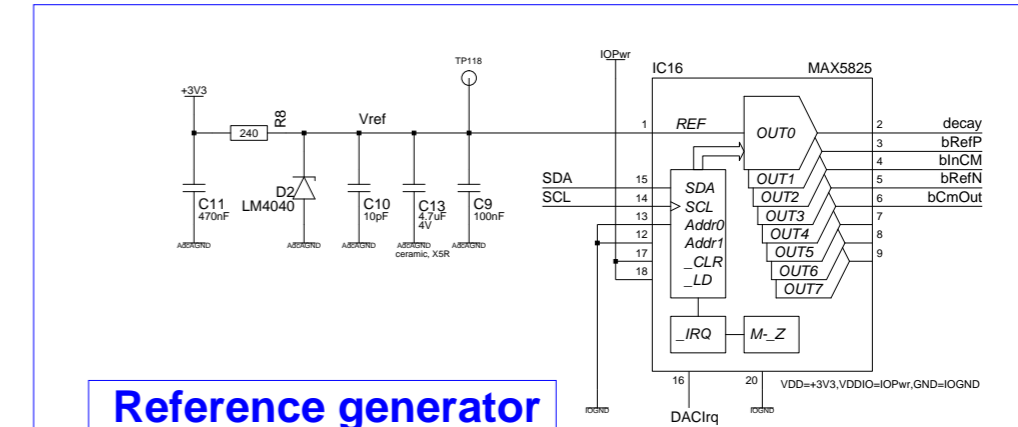

Engineer Bjorn Lundberg	Particle Physics Lund University Lund, Sweden	
Drawn by Bjorn Lundberg	TITLE: SAItro16 Testboard	Size A3
R&D CHK	MCM-prototype	
MFG ENGR CHK	ILCTPC	
QA CHK	REV 1.0	Drawing Number 1
Changed by	Date Changed Sun, Sep 01 2013	Time Changed 23:13
	Sheet 1 of 3	

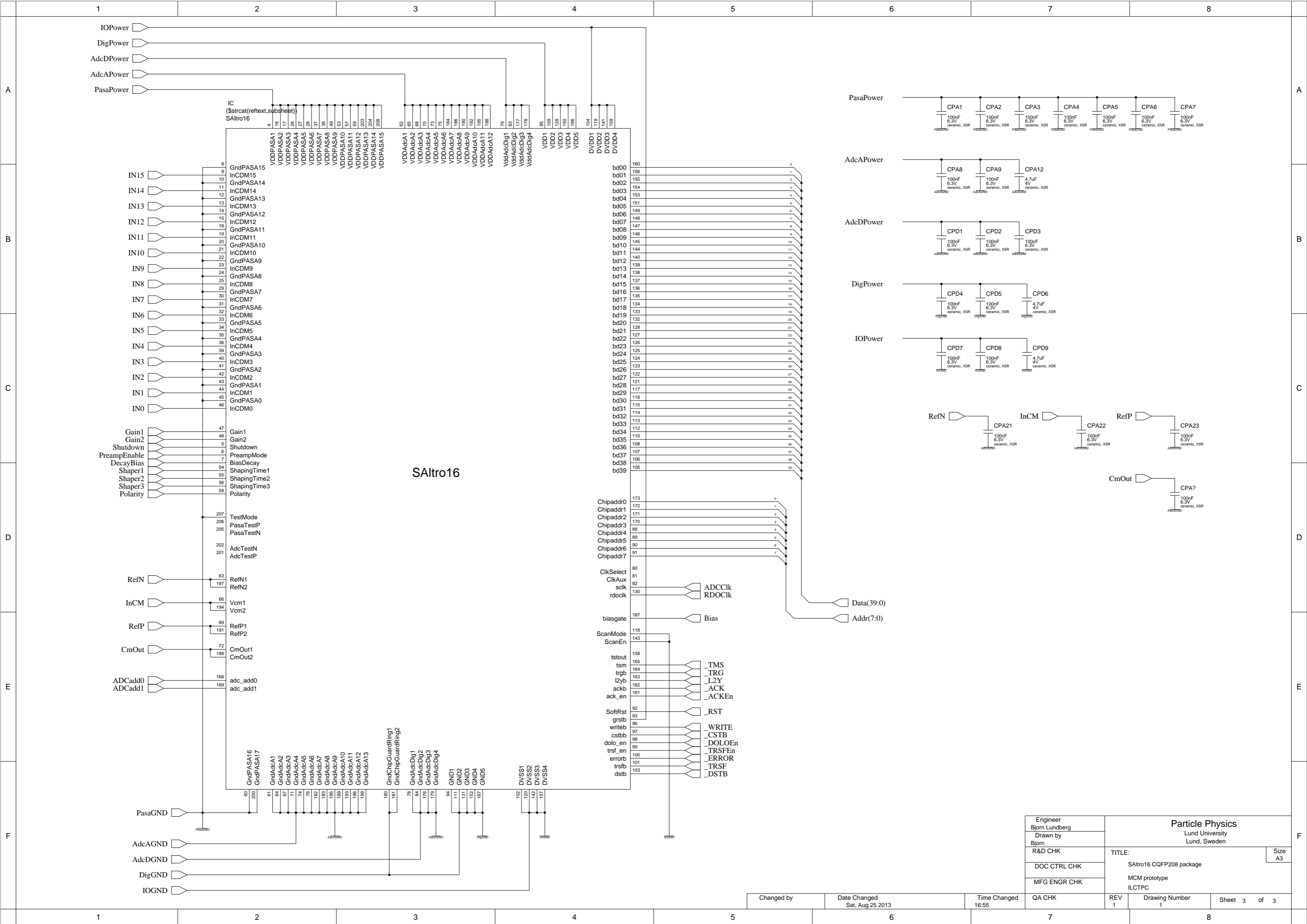

SA1tro16

Engineer Bjorn Lundberg	Particle Physics Lund University Lund, Sweden		
Drawn by Bjorn	TITLE: SA1tro16 CQFP208 package		
R&D CHK	MCM prototype		Size A3
DOC CTRL CHK	ILCTPC		
MFG ENGR CHK	REV 1	Drawing Number 1	Sheet 3 of 3

Changed by	Date Changed Sat, Aug 25 2013	Time Changed 16:55
------------	----------------------------------	-----------------------

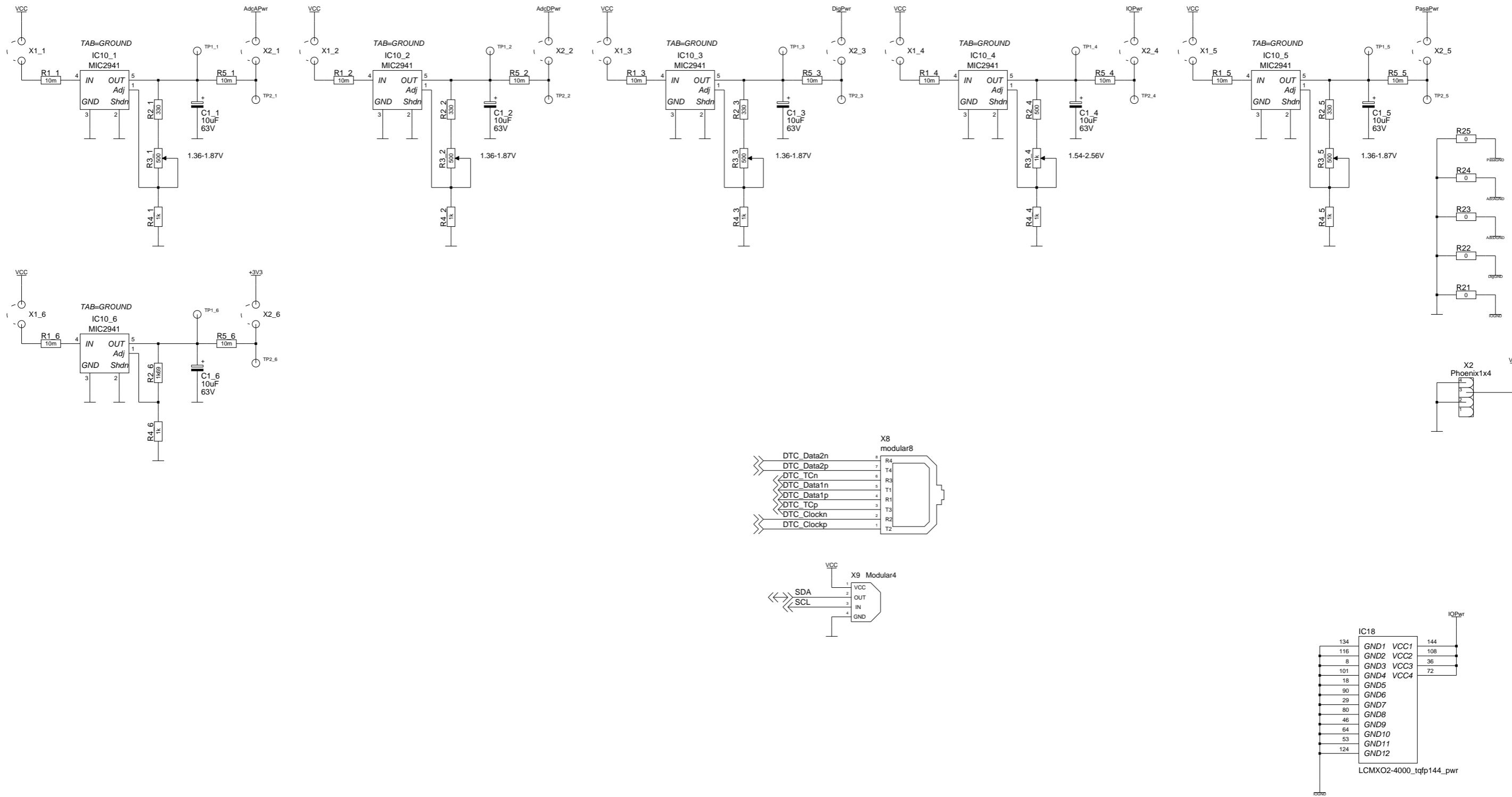

Engineer Bjorn Lundberg	Particle Physics Lund University Lund, Sweden		Size A3
Drawn by Bjorn			
R&D CHK	TITLE: SAltro16 Testboard		
DOC CTRL CHK	MCM-prototype		
MFG ENGR CHK	ILCTPC		

Changed by	Date Changed Sun, Aug 25 2013	Time Changed 14:36	QA CHK	REV 1.0	Drawing Number 1	Sheet 2 of 3
------------	----------------------------------	-----------------------	--------	------------	---------------------	--------------